



INSTALLATION INSTRUCTIONS

KYMCO

UXV 700i SPORT

SAFETY INSTRUCTIONS

Warning: Failure to heed all safety and operating instructions and warnings regarding use of this product can result in serious bodily injury.

READ PROPERLY COMPLETE ASSEMBLY INSTRUCTIONS BEFORE STARTING THE ASSEMBLY

Install all parts indicated in assembly instructions. Failure to fully assemble product before use could result in personal injury.

Assembly of product requires use of hand or power tools. If you are not experienced in using these types of tools, have a product dealer do the install for you.

Some parts contain sharp edges, wear protective gloves if necessary. Always keep your assembly area clean, uncluttered and well lit.

Keep visitors and children a safe distance away from the assembly area. Visitors should wear the same safety equipment described under.

Never operate your UTV with the cab doors open. Failure to properly latch the doors before moving the vehicle could result in serious injury.

Dress for safety. DO NOT wear loose clothing, gloves, neckties or jewelry if using power tools to assemble this product. Insert all nut covers after you finish installation.

Never drive your UTV with the cab front window in open position. Failure to properly latch/lock front window before driving the vehicle could result in serious injury.

MAINTENANCE AND CLEANING

To clean polycarbonate surface use soapy water solution or other subtle means.

Wash off dirt and dust wash with a gentle water stream and wipe only with wet or damp cloth/sponge from top to bottom.

The recommended frequency of cleaning of polycarbonate panels is about 1 time per month or according to the actual degree of dirtiness.

Do not use detergents that could scratch the surface panels. (abrasives, harsh fabrics, etc.)

Do not use solvents or alkaline detergents or cleaners with ammonia (ammonium hydroxide).

Do not remove the impurities from the surface with razor blades or other sharp items.

Do not clean cab when the polycarbonate panels are hot from the sun.

Do not use a squeegee as it could scratch surface panels.

Do not power wash with a current strength greater than 725 psi

The manufacturer is not responsible for scratches on the surface if user fails to comply with the above instructions.

All bolted connections of cab must be checked and tightened by user at regular intervals.

PREPARATION FOR INSTALLATION:

Remove all additional systems from the roll cage (work lights, rear mirrors, drink holders etc.)

CAB PREVIEW

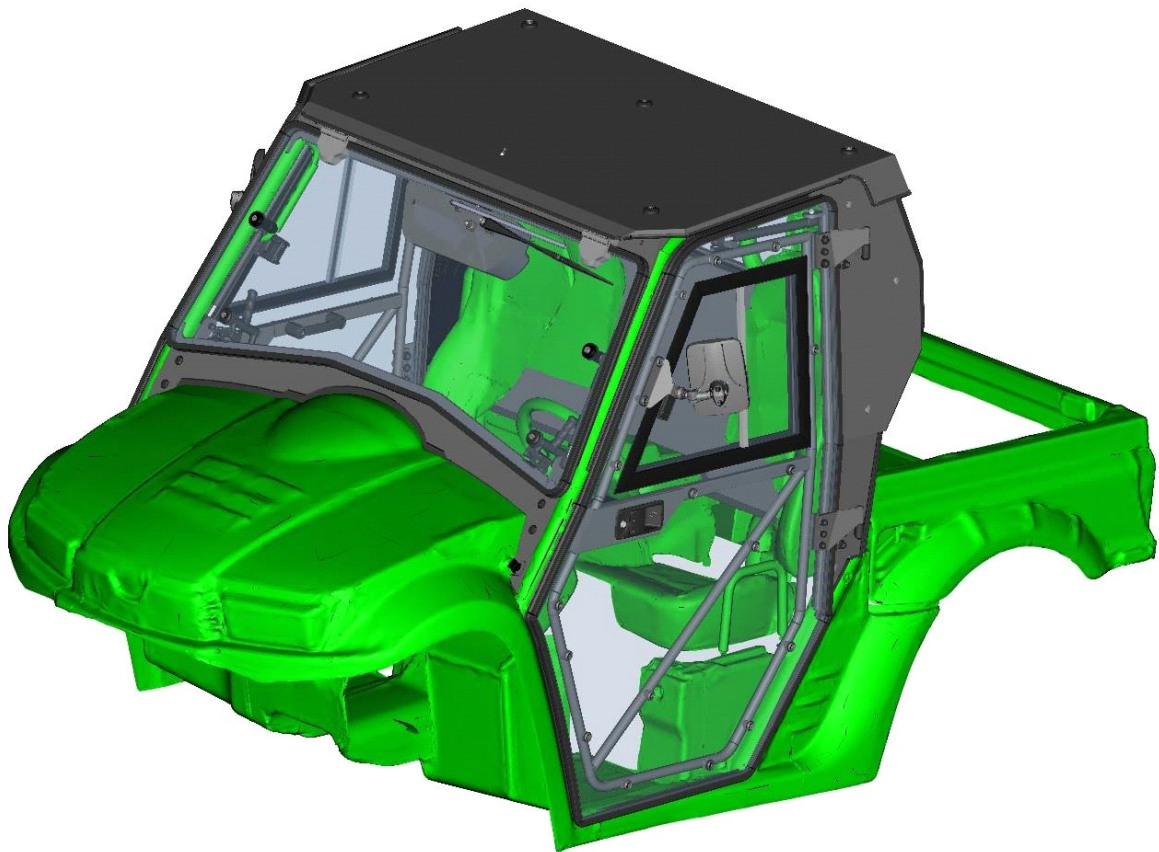

4

HEATER INSTALLATION

Open the glove box and remove the glove box hinges screws.



5

Remove the glove box door from the dashboard.



Remove the two screws fixing the glove box door stop. Remove the glove box door stop.



Drill two holes \varnothing 28 mm into the bottom of the glove box for the heater water hoses.



Route the heater water hoses through the prepared holes.



Mount the heater holder onto the dashboard with original plastic push pin rivets.



Drill the third hole \varnothing 20 mm to the bottom of the glove box next to the other holes.

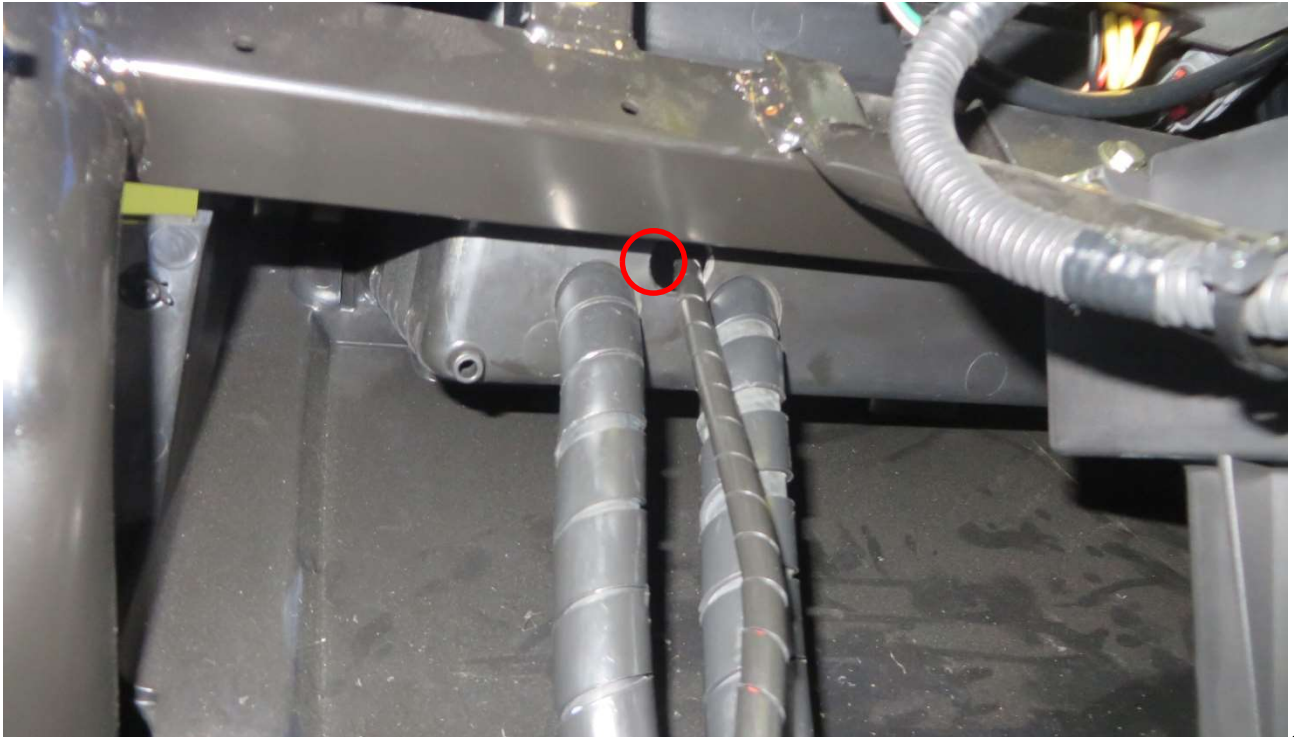

Route the heater harness and the water pump harness through the prepared hole.

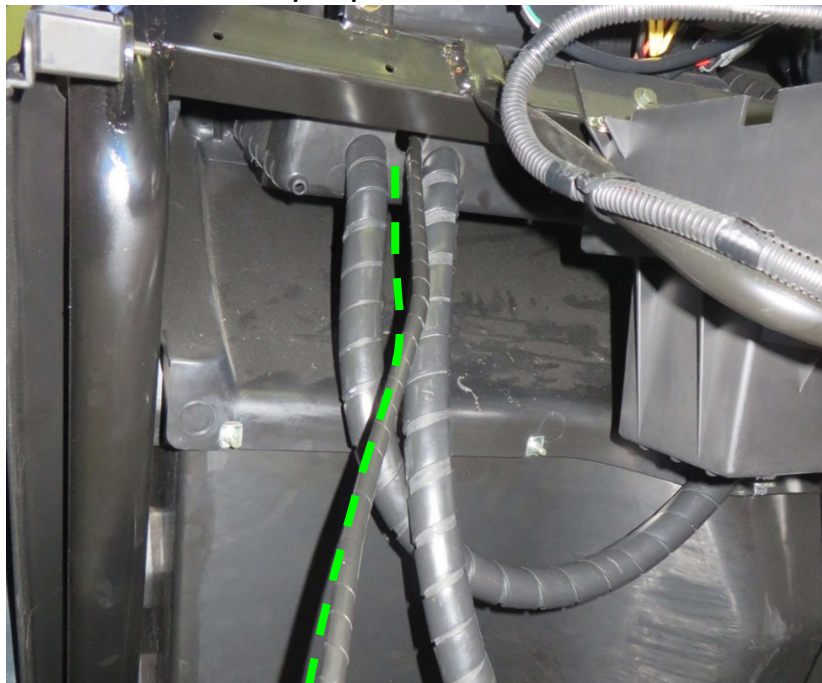

10

Mount the heater water hoses onto the electromagnetic valve (heater input) and onto the bleeding valve (heater output). Attach the hoses with included tightening straps.

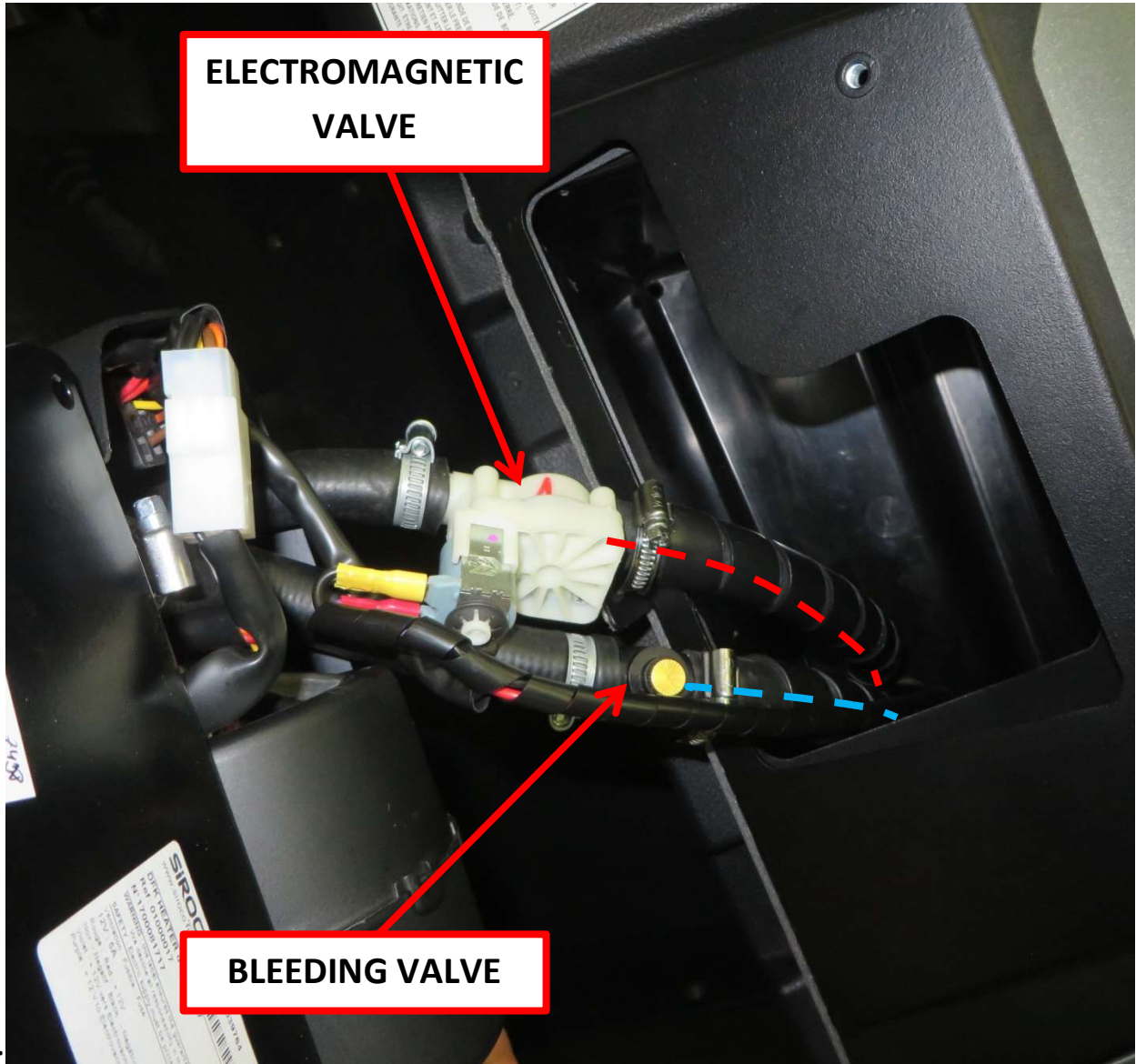

11

Connect the water pump harness and the heater harness to the electromagnetic valve.

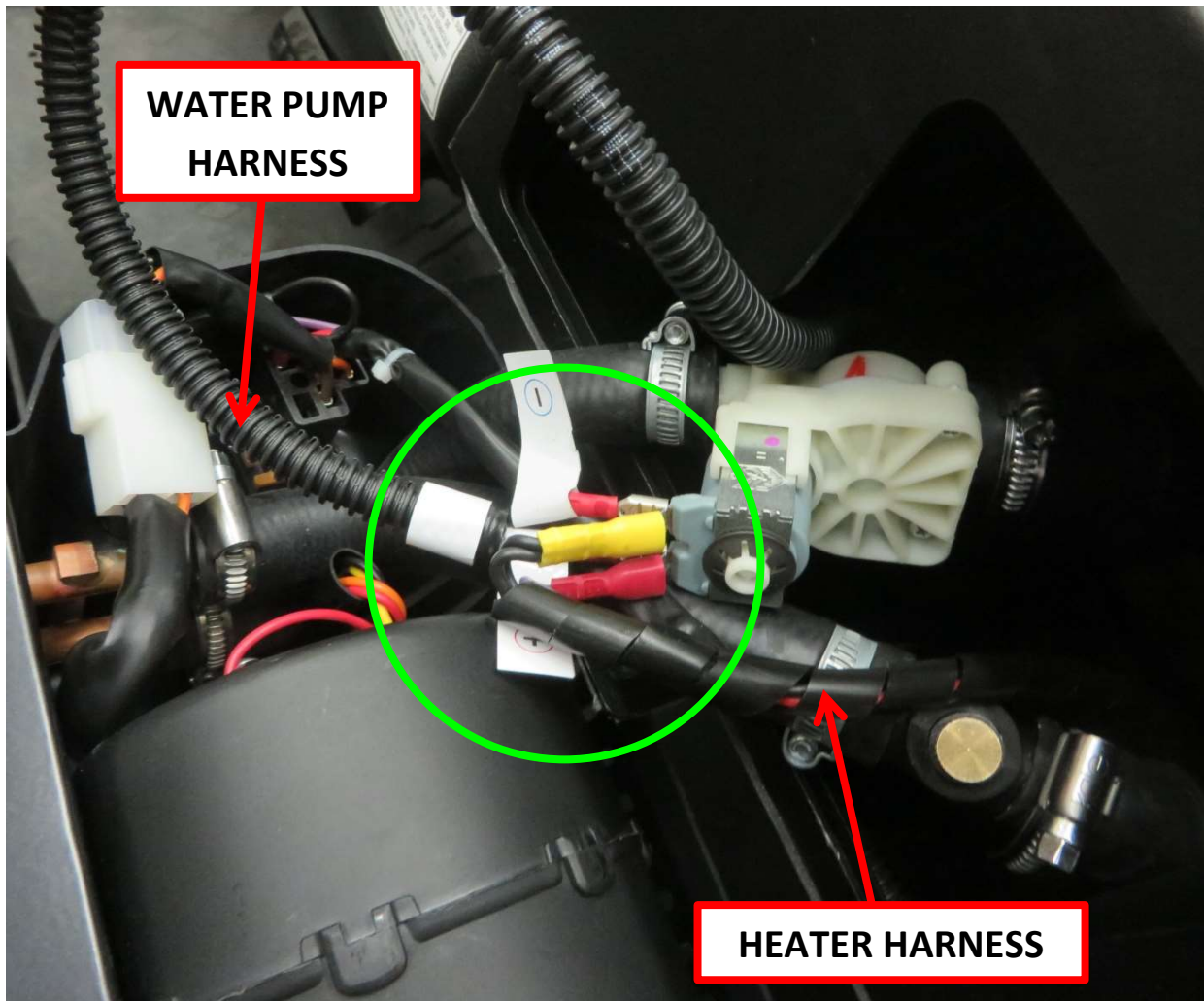

12

Remove the seats from the vehicle.



Remove the screw from the shift lever (red circle) and then remove the shift lever.



Remove the screws at the front of the plastic central cover (red circles).



Remove the plastic central cover from the vehicle.



15

View on engine space without the seats and the plastic central cover.



16

Route the heater input water hose from the heater to the engine space.

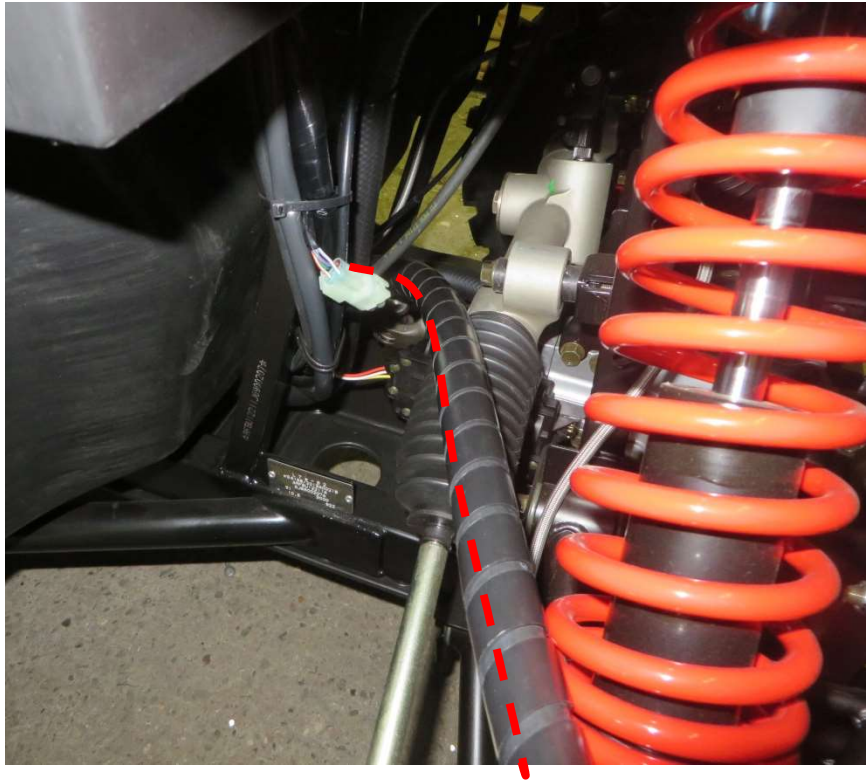

Route the heater input water hose under the floor to the engine space.

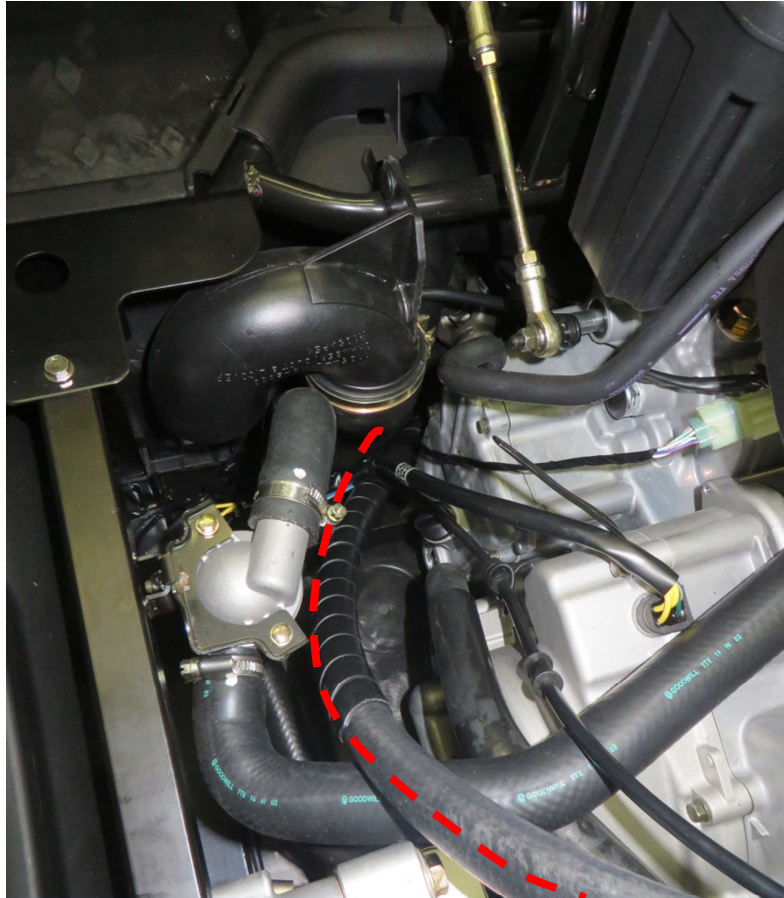

Shorten the hose to the correct length and install the “Y” coupling on the end of the hose. Attach the “Y” coupling with included tightening strap.

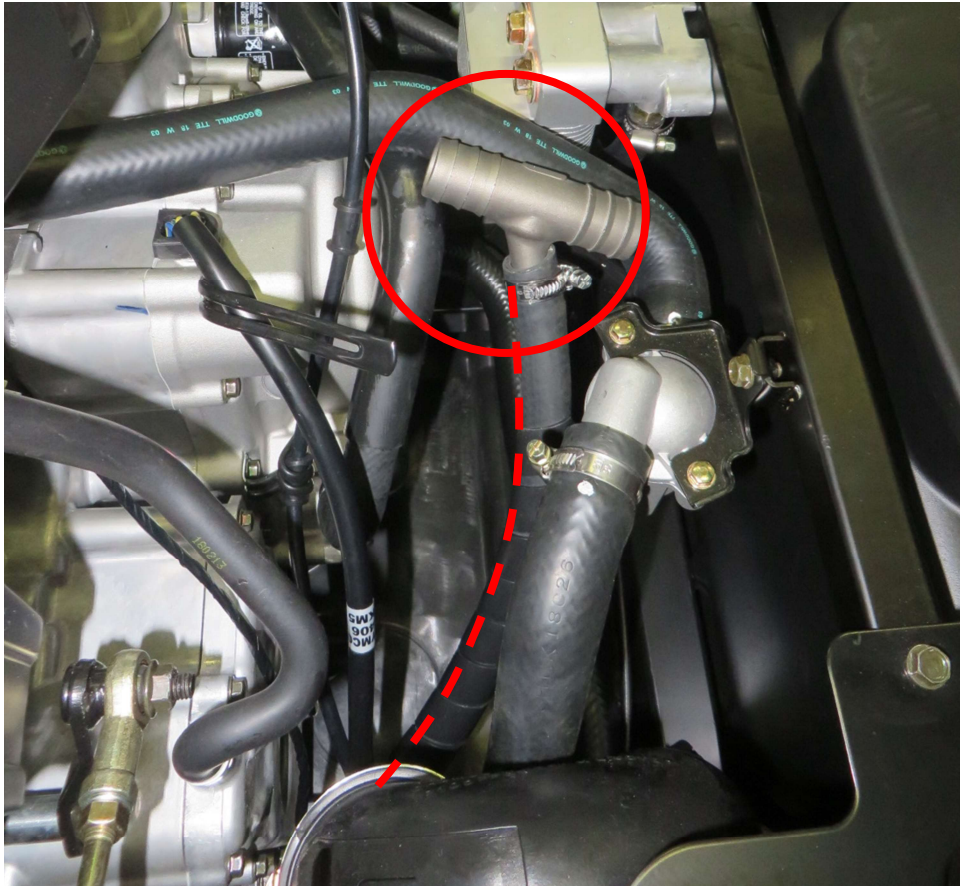

Secure the original cooling system hose with the clamps.



Cut the original cooling system hose between the clamps.

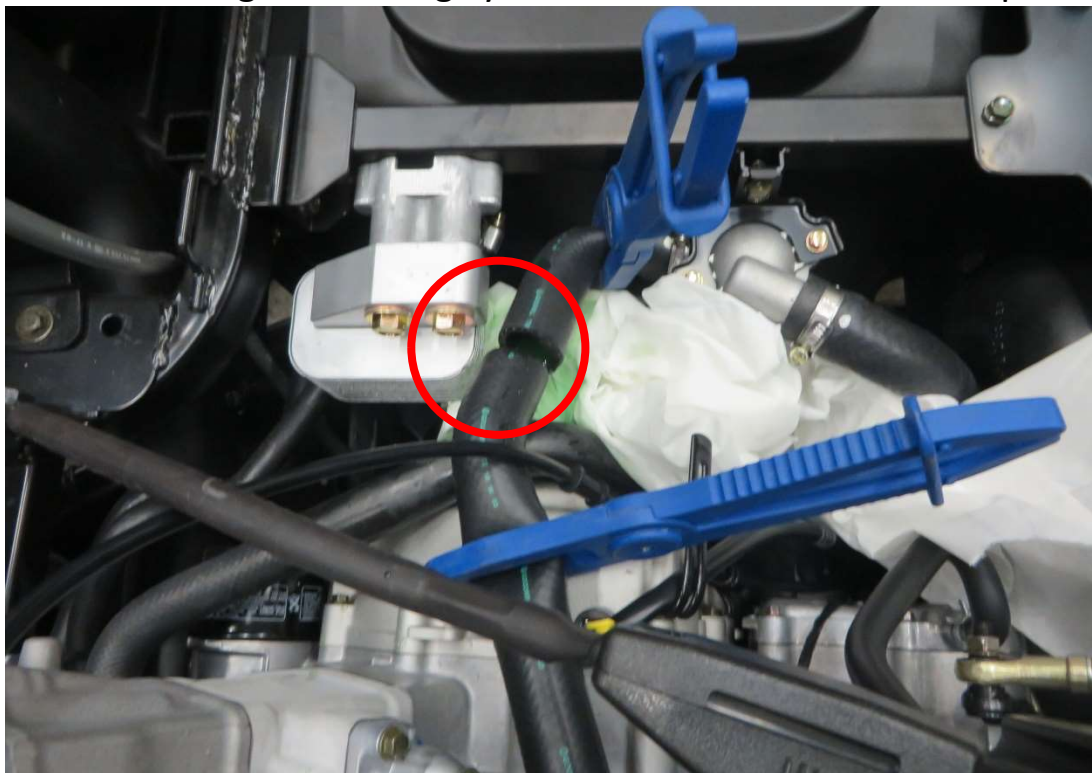

Install the “Y” coupling between the cutted hose. Attach the coupling with included tightening straps.



Cut the heater input water hose and install the water pump. Attach the water pump with included tightening straps.



Connect the water pump harness with the water pump.

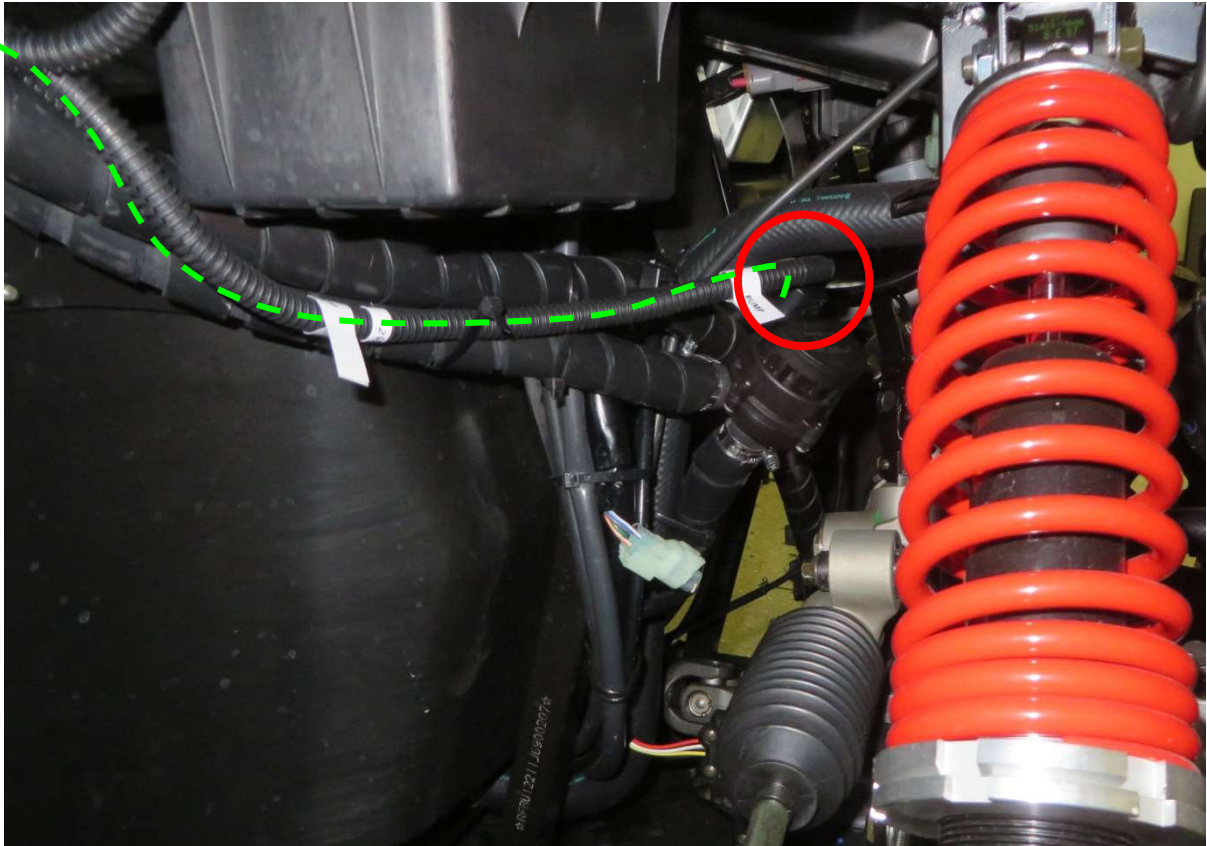

Detail view of the water pump harness connection.

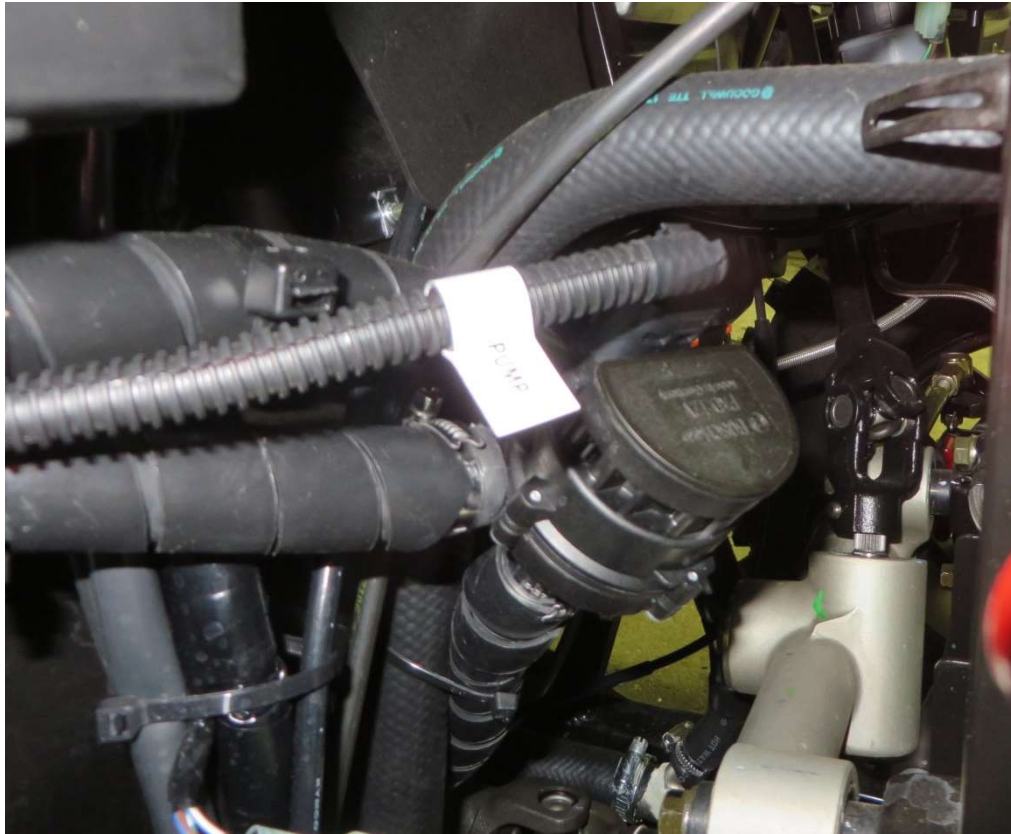

Route the heater output water hose from the heater to the left front wheel space.

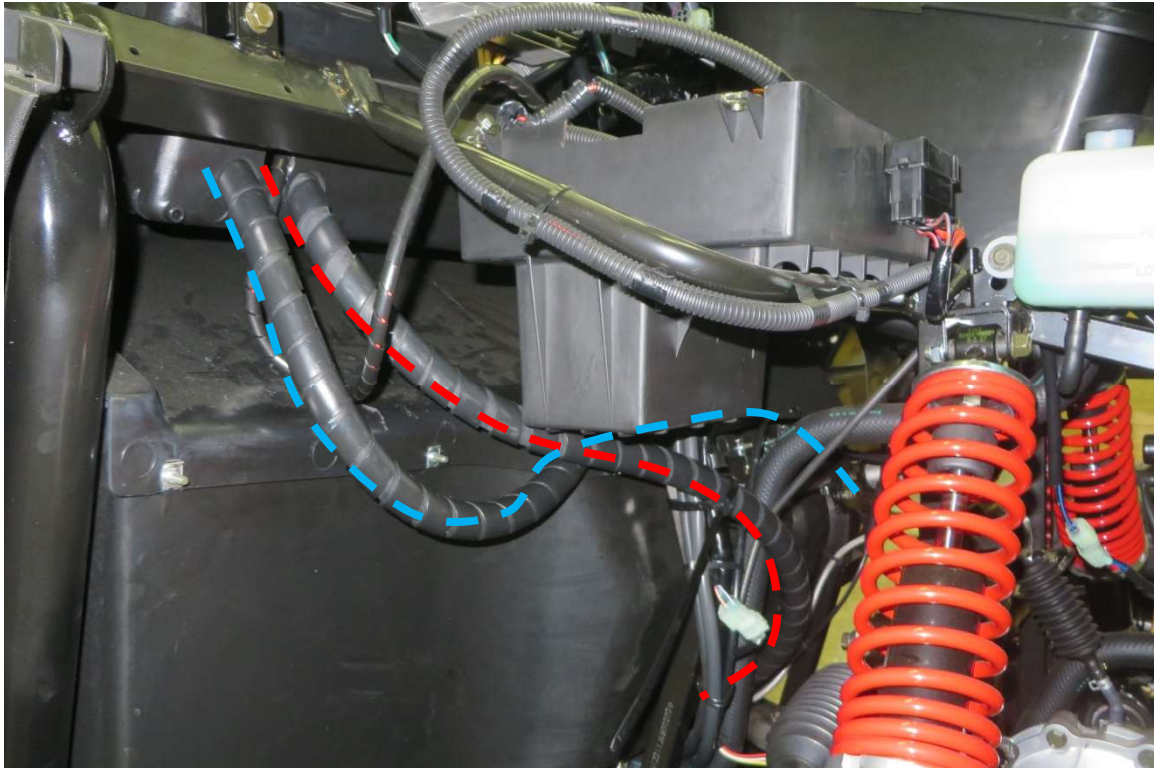

Look for the original cooling system hose.

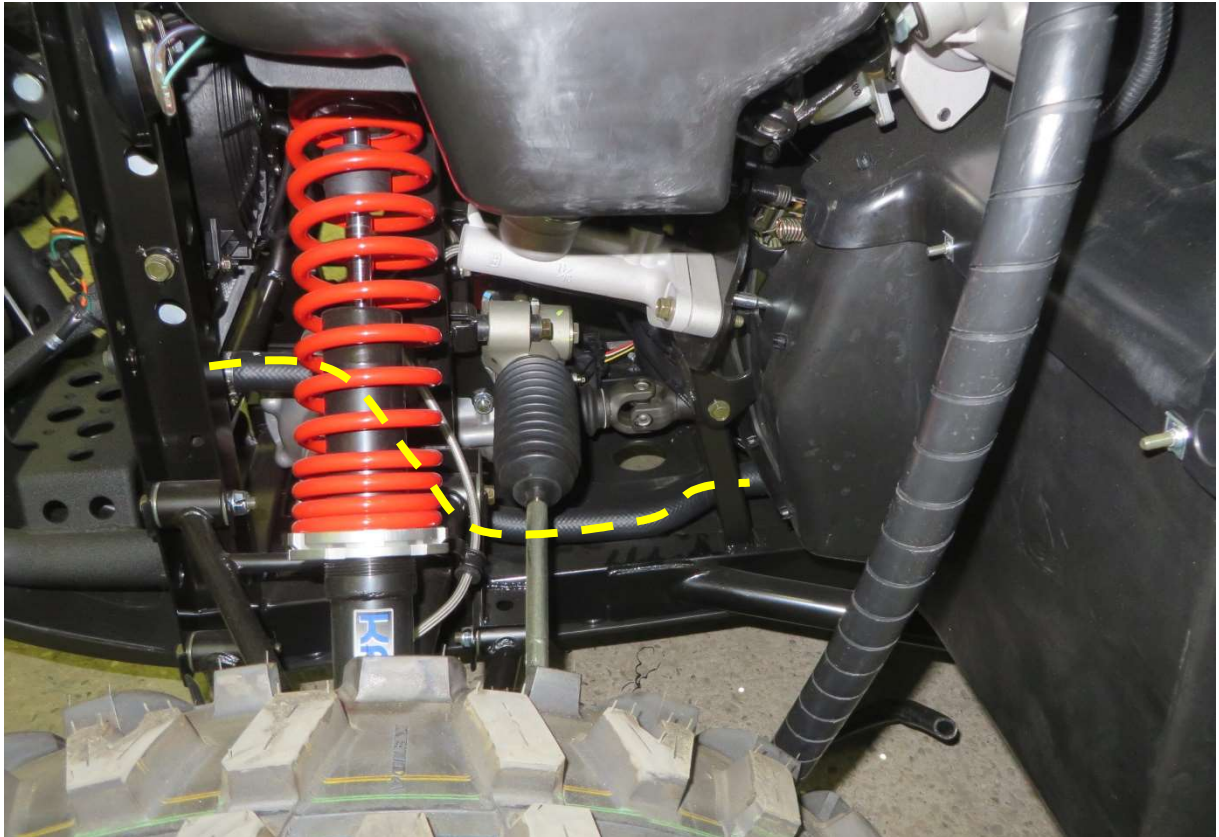

Secure the original cooling system hose with the clamps.



Cut the hose between the clamps. Install the “Y” coupling between the ends of the original cooling system hose.

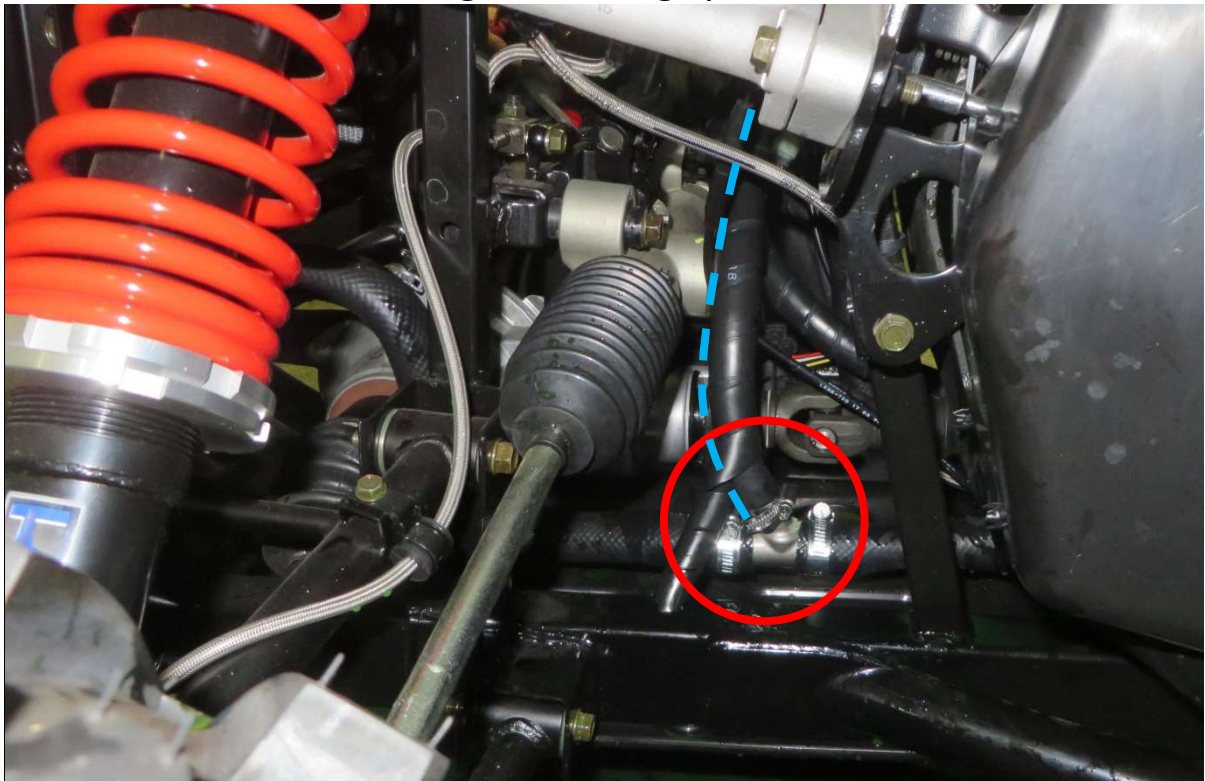

Attach the heater with included screws on both sides.



Remove four screws around the original electroinstallation box.

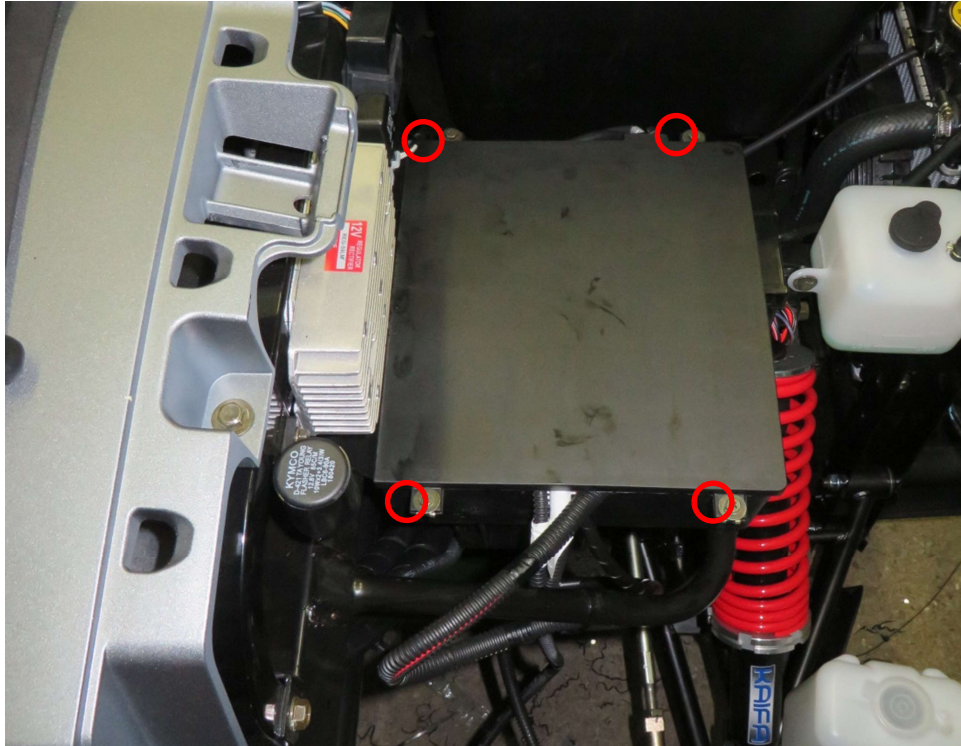

Look for the the original electronstallation relay.

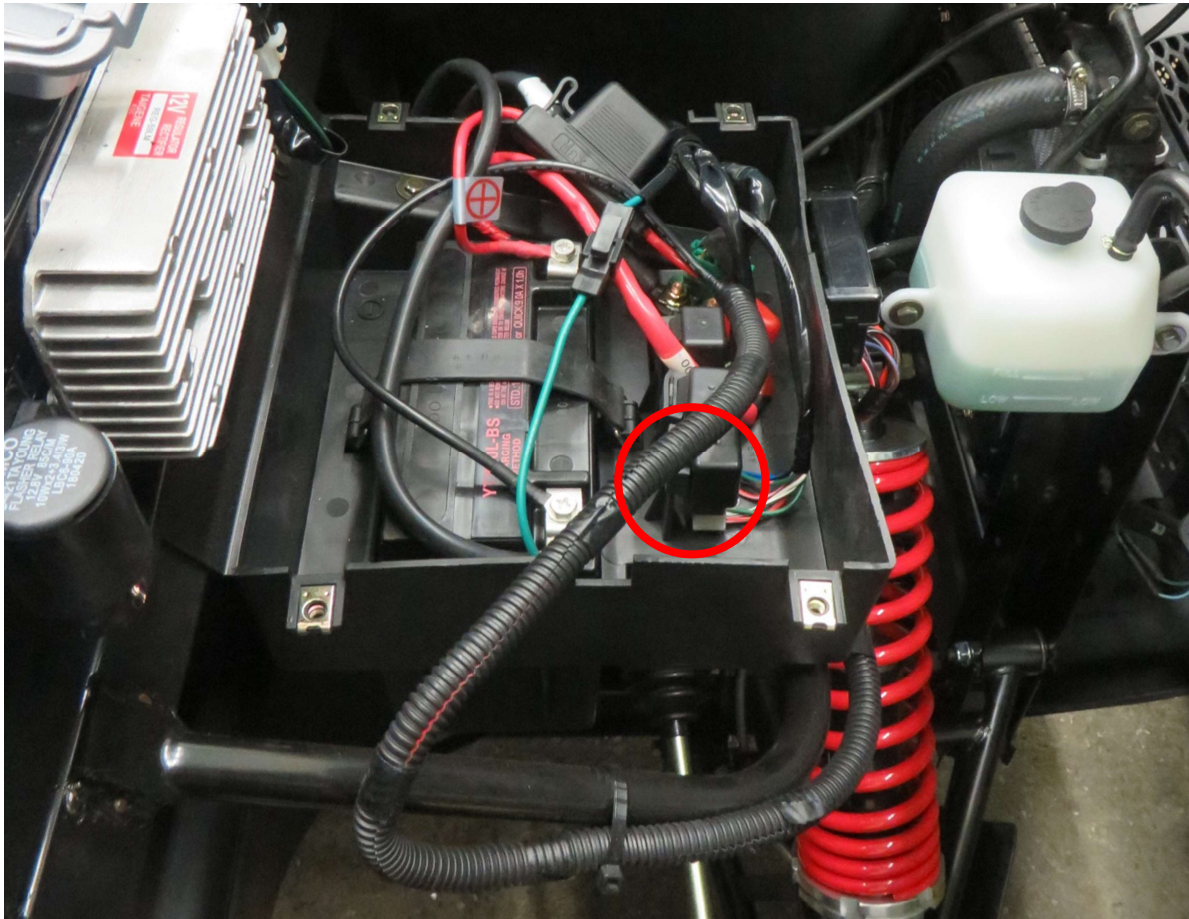

Remove the original relay from the connector.

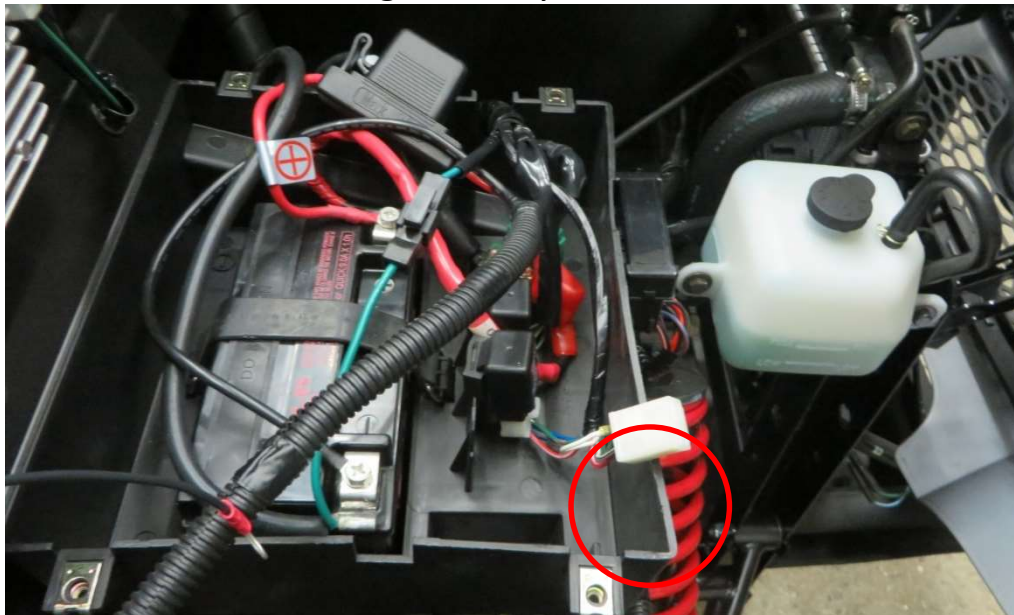

Detail view on the original relay connector.

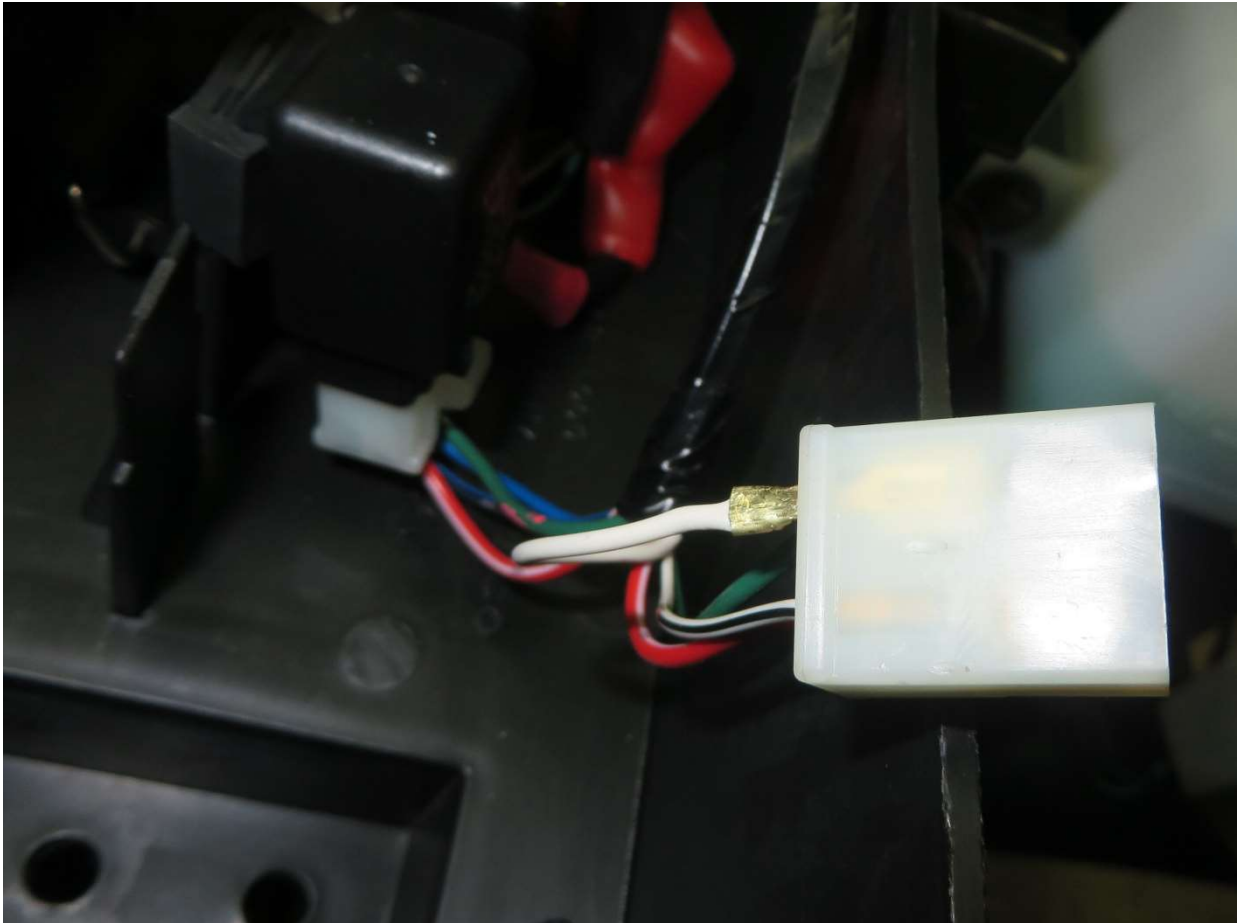

32

Remove the white wire from the original connector.

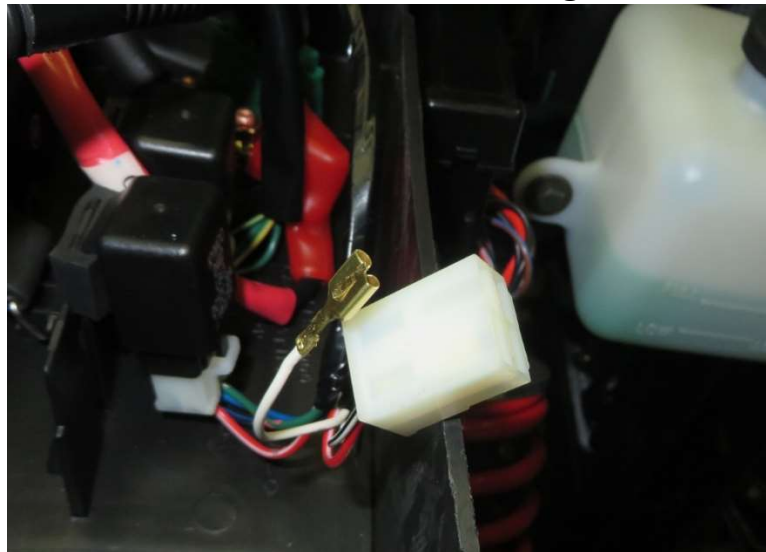

Connect the white wire from the connector with the relay harness white wire.

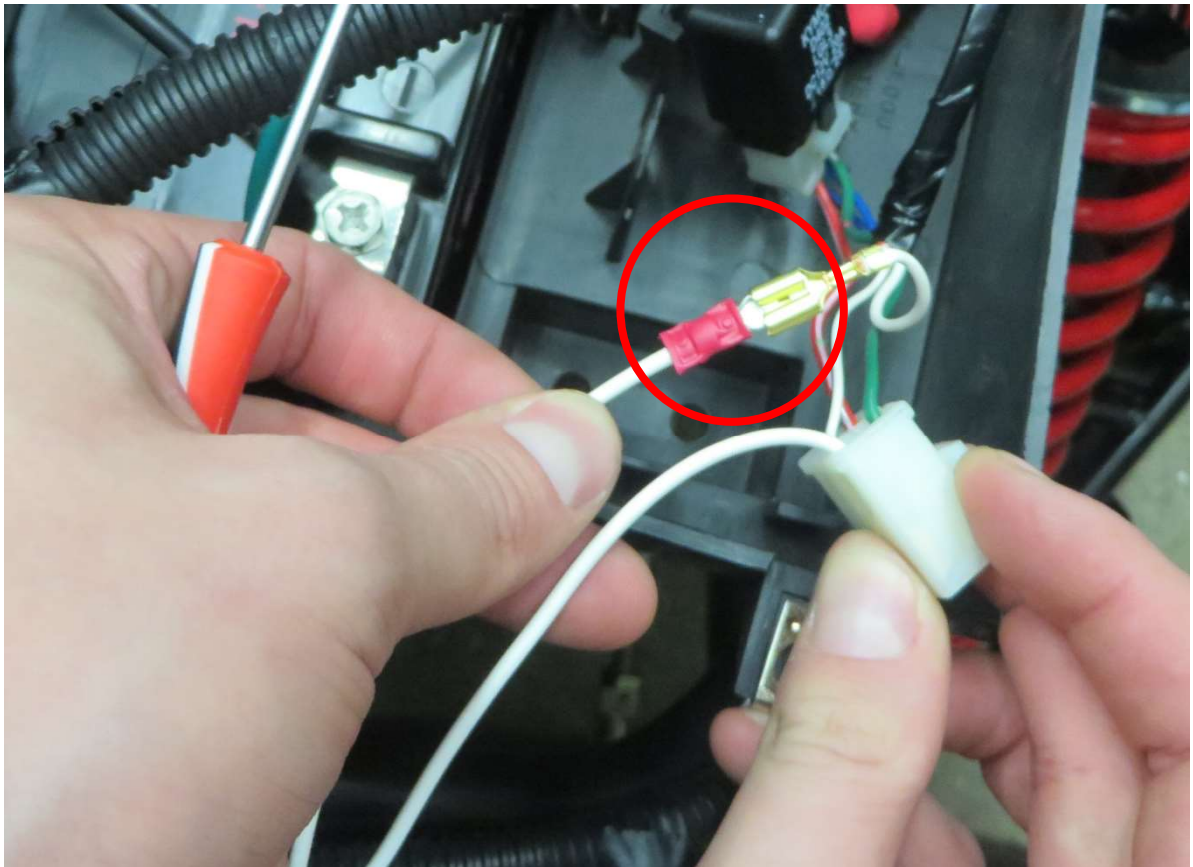

Secure the wires connection with electrical tape.

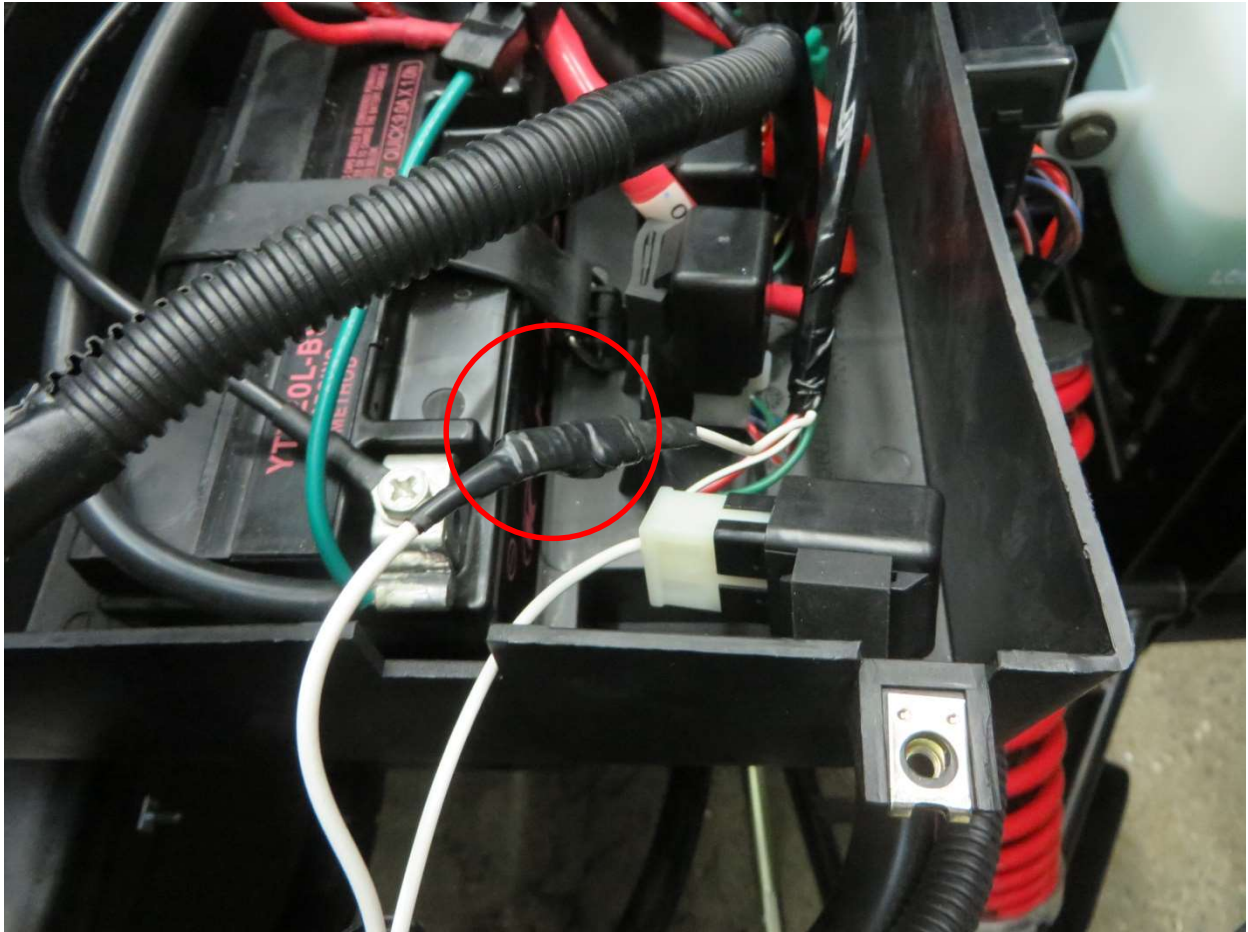

Install the original relay back to the connector and place the relay back to the original position. Connect the relay harness to the (+) and (-) battery terminals.

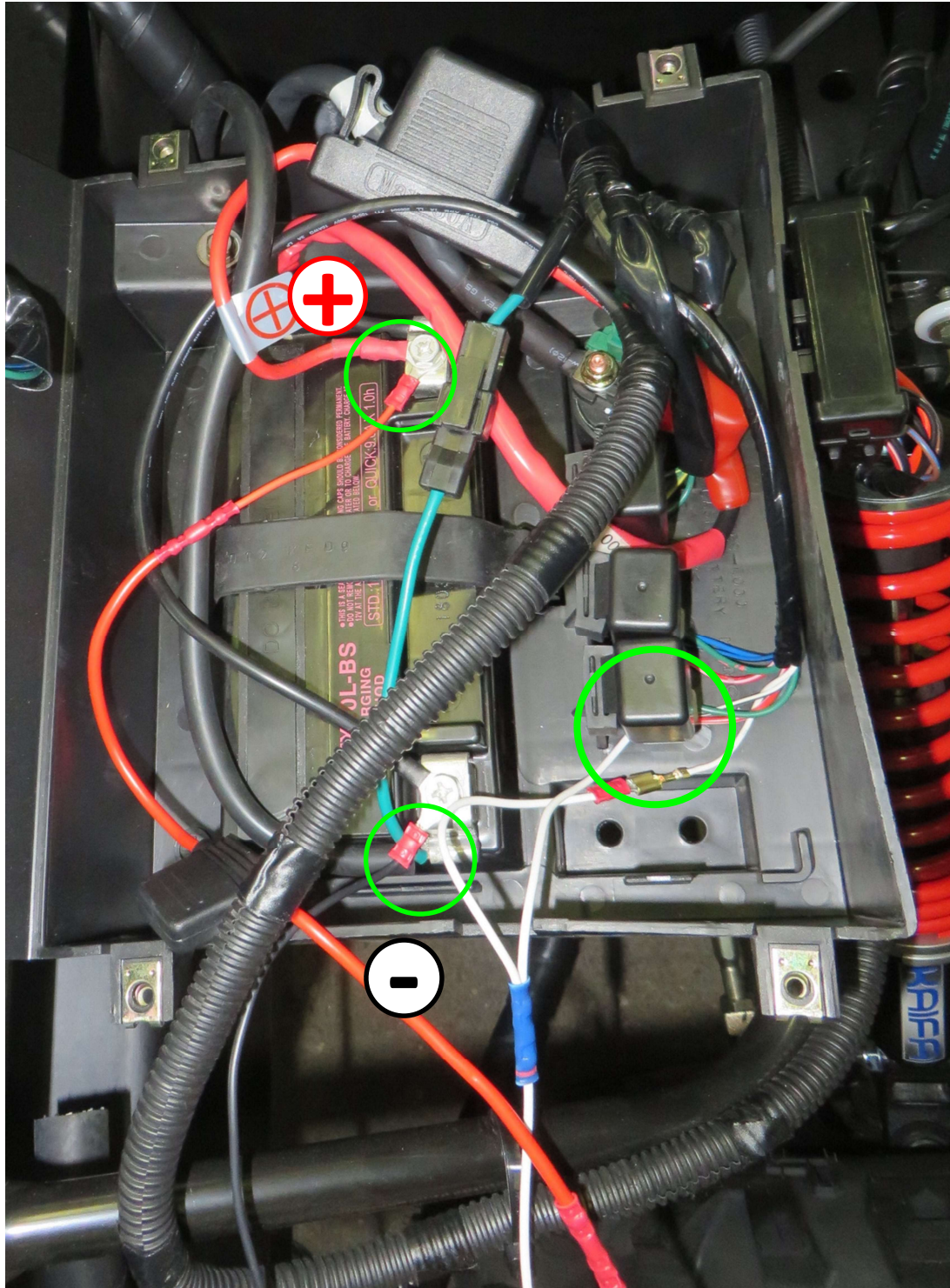

Connect the power supply harness with the relay harness.

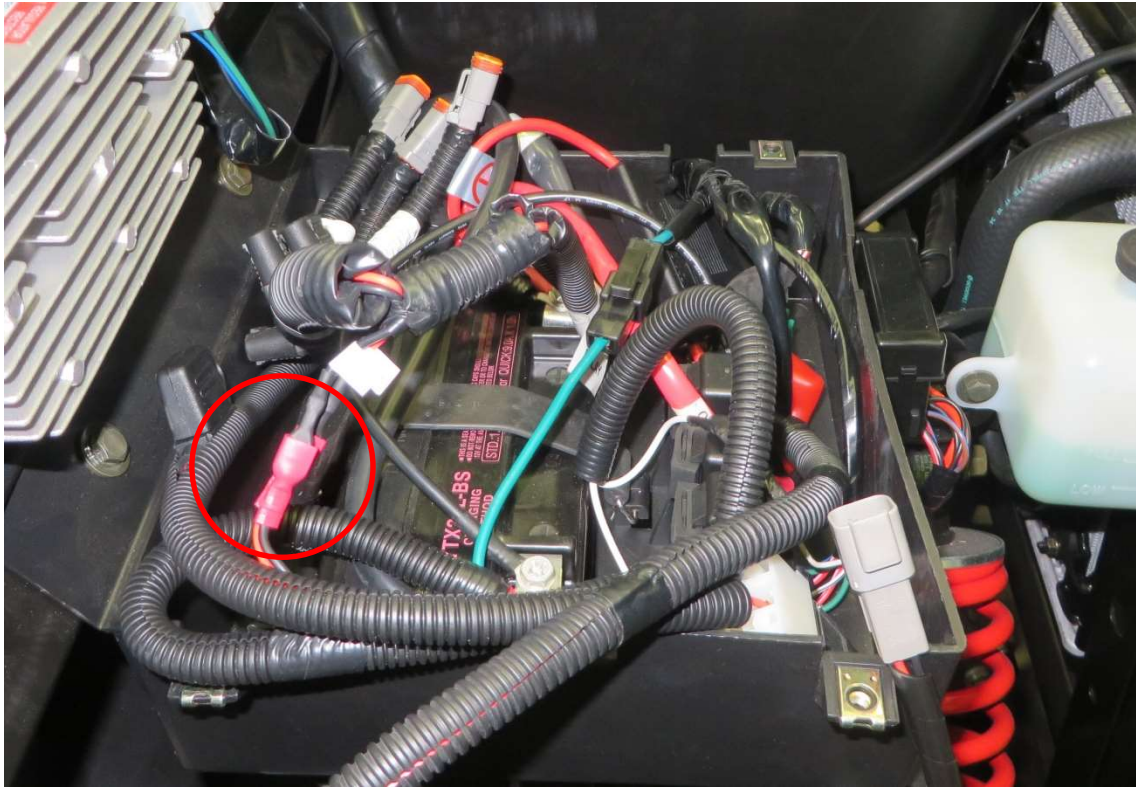

Detail view of the connection.



Extend the original hole on the electroinstallation box for the additional harness.



37

Connect the power supply harness with the heater harness, wiper harness and washer harness.

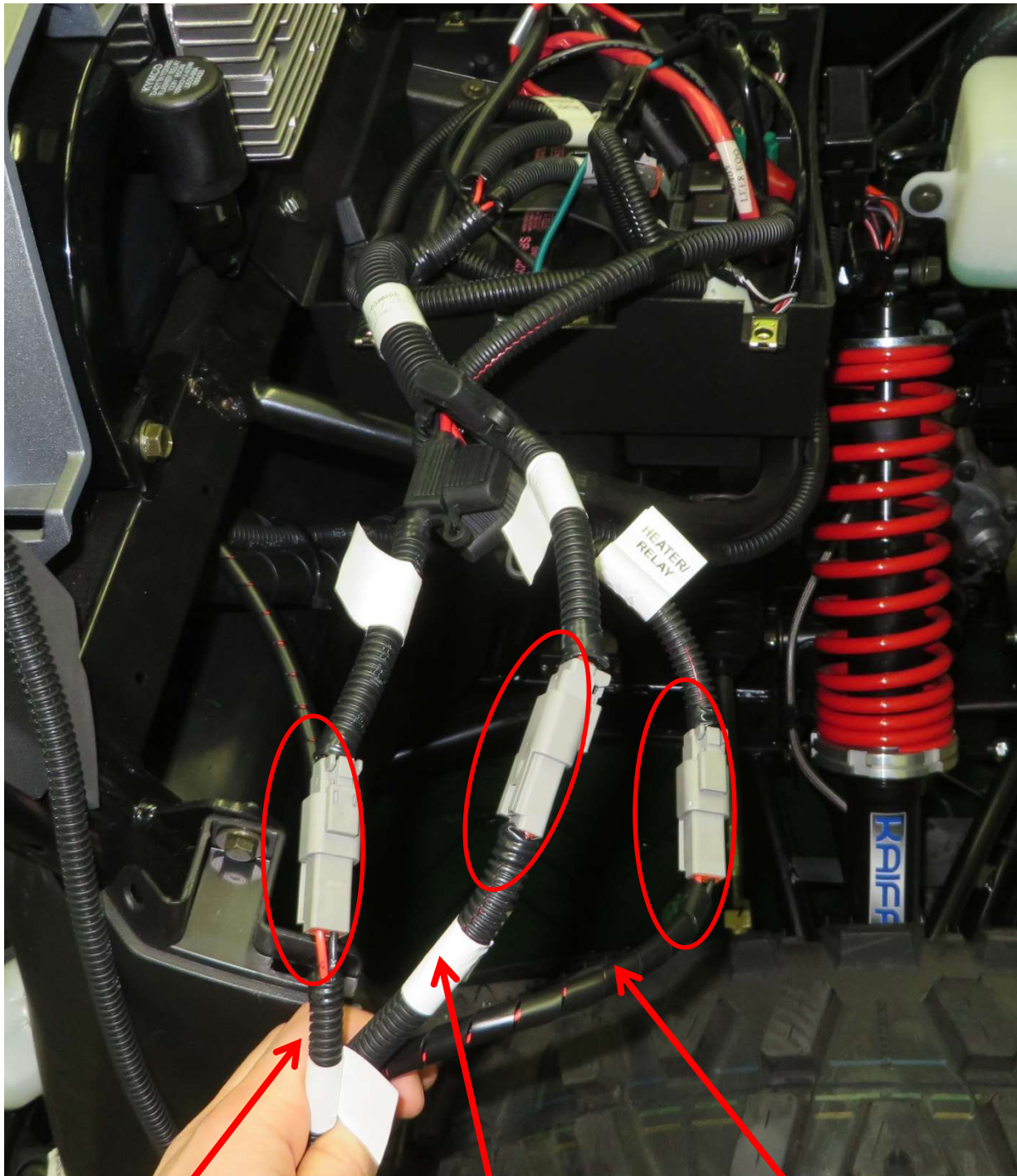

38

WASHER HARNESS

WIPER HARNESS

HEATER HARNESS

Roll out the washer harness for easiest connection.



Connect the washer harness and the water tube with the washer tank.



Drill the hole \varnothing 10 mm to the plastic cover under the hood. Mount the washer tank holder with included fixing assembly.

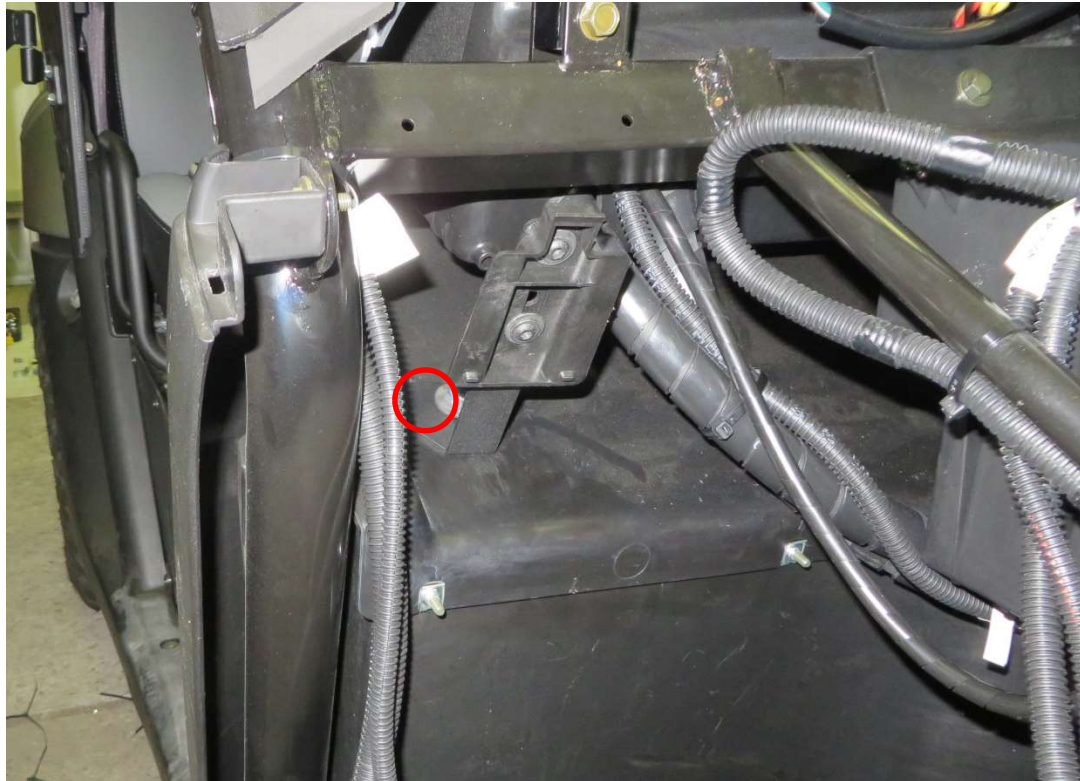

Route the washer harness and the wiper harness up next to the right ROPS frame tube.



42

Route the wiper and washer harness up onto the right ROPS frame tube.



43

Mount the wiper motor on the windshield from the inside.



Inside view on installed wiper motor.



Route the harness from the wiper motor to the right side of the vehicle.



45

Connect the washer tube from the washer harness and the harness from the wiper motor together.

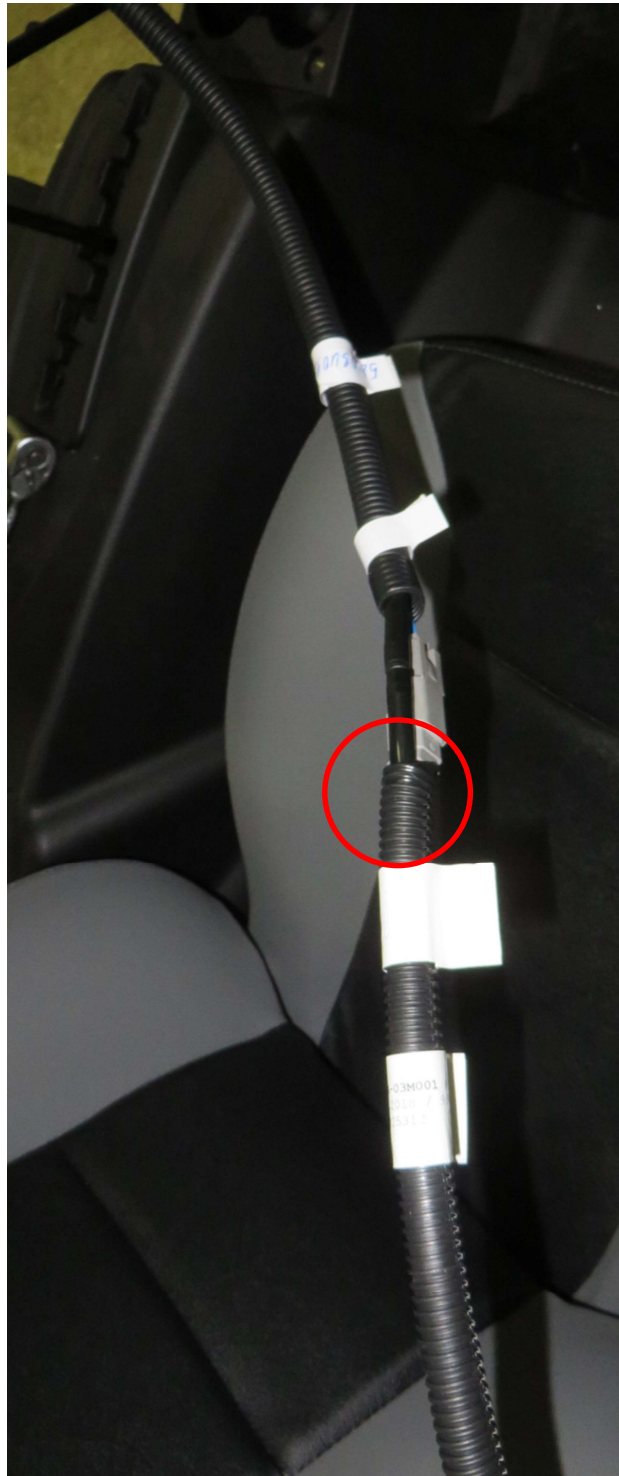

Connect the wiper harness and washer harness with the wiper motor harnesses.

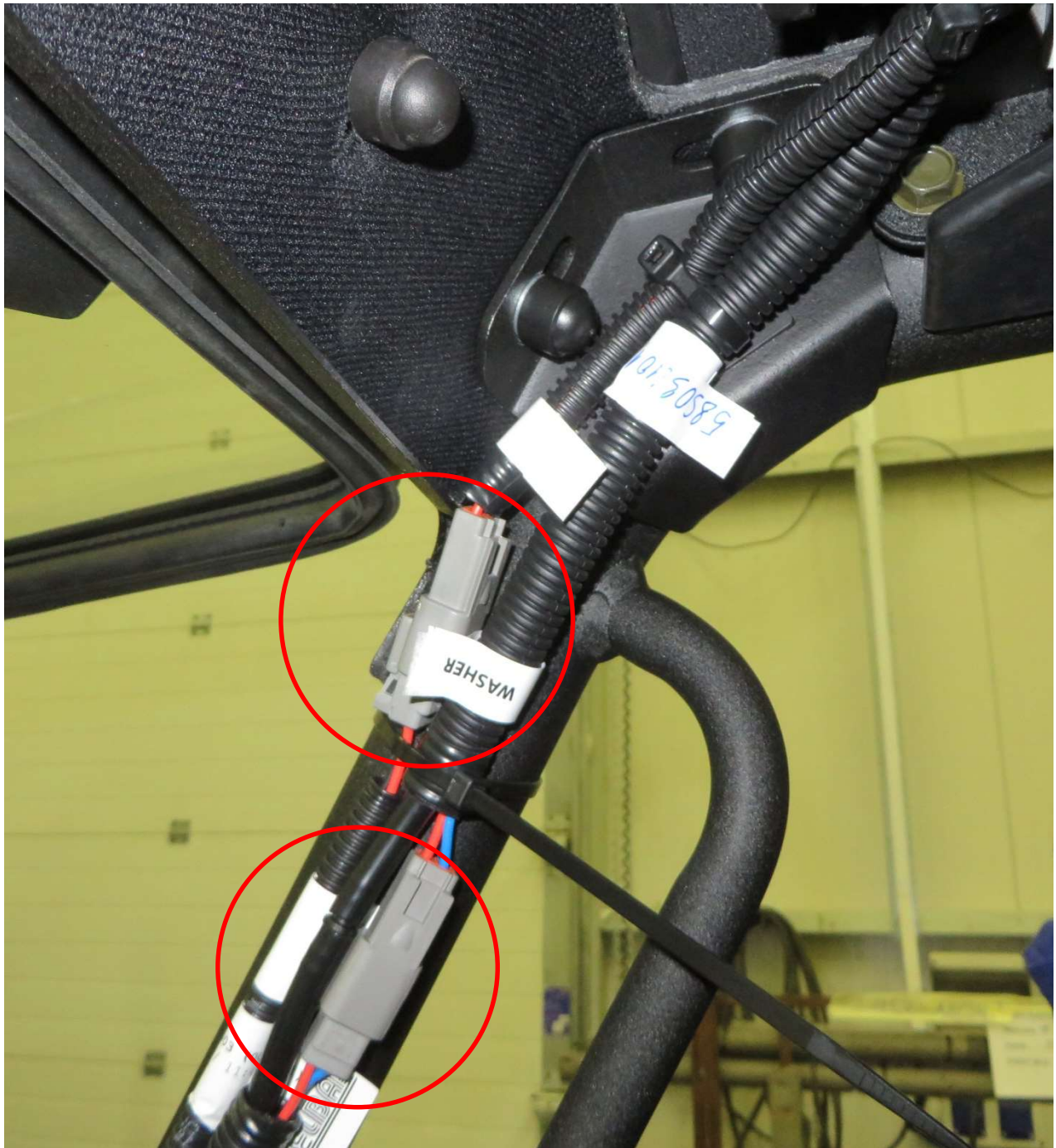

47

Attach the wiper and washer harness with included tightening ties to the UTV ROPS.



Install the washer tank onto the washer tank holder.



Mount the central plastic cover and the seats back to the original position.



50

Manage the harnesses inside the electroinstallation box

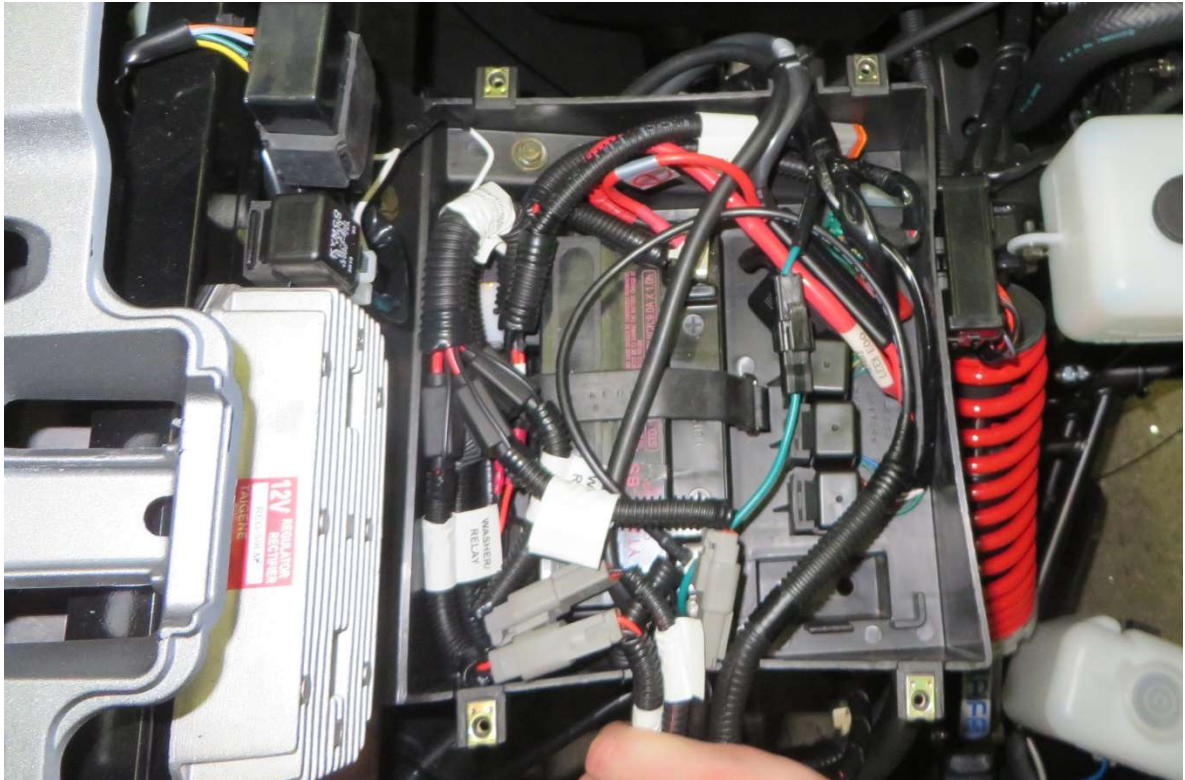

Close the electroinstallation box and attach the box cover with four original screws.



CAB INSTALLATION
FRONT PANEL

Remove the hood fixing rubber bands from the hood.



52

Place the front bottom ledge onto the UTV frame and the UTV body.

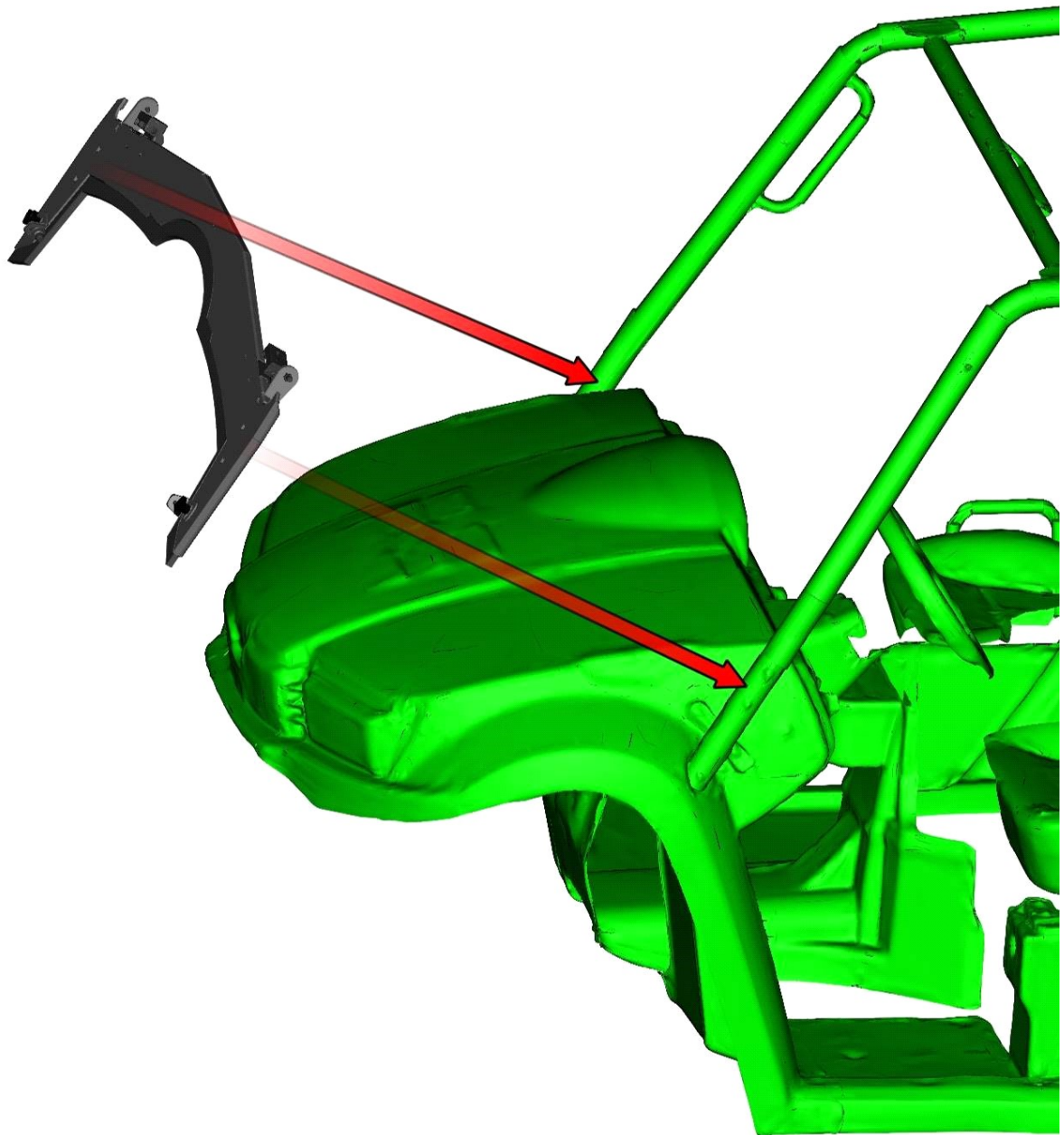

Place the front bottom ledge holder onto the front bottom ledge and the UTV frame on both sides..

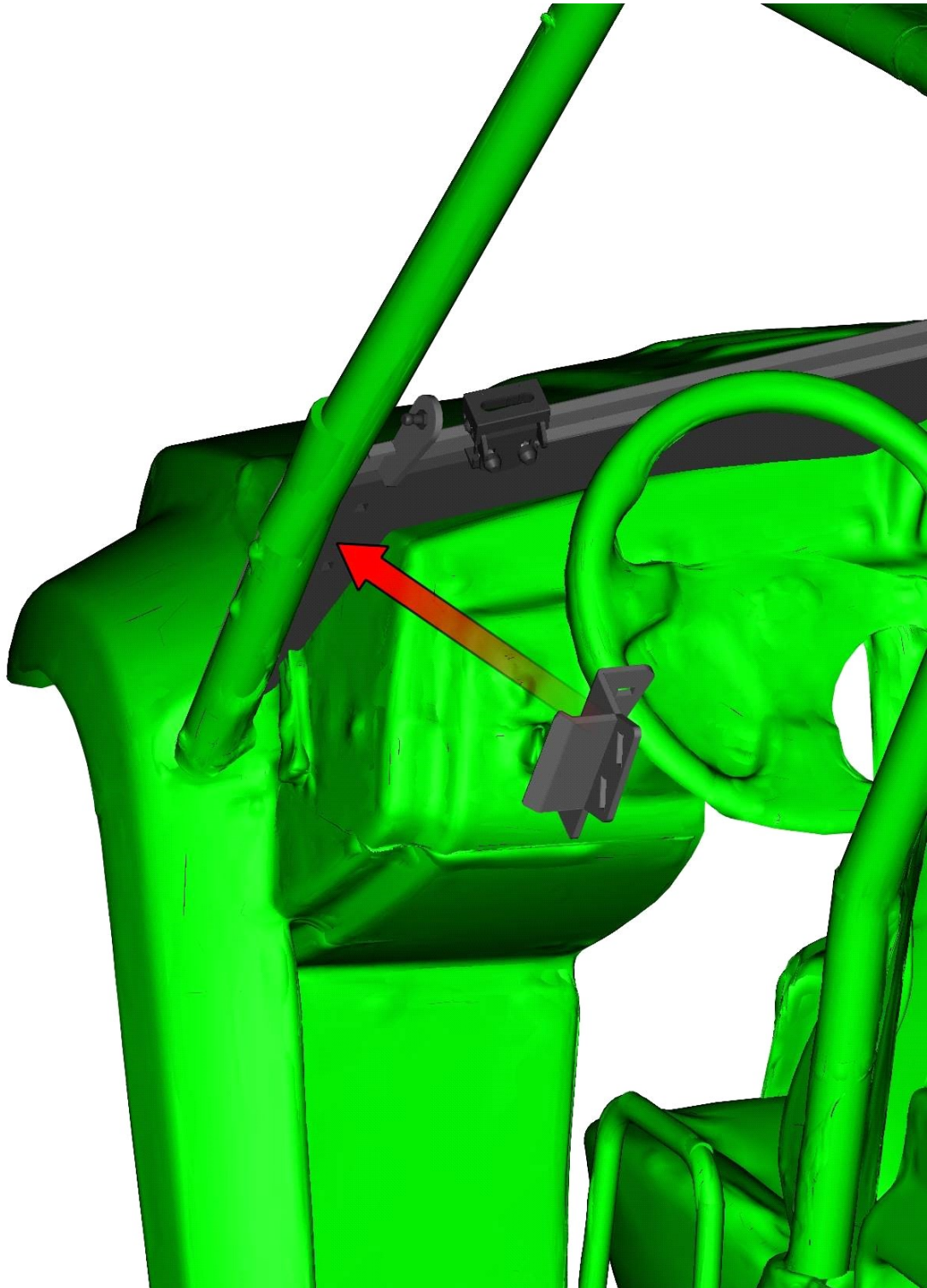

54

Attach the front bottom ledge holders with included fixing assemblies on both sides.

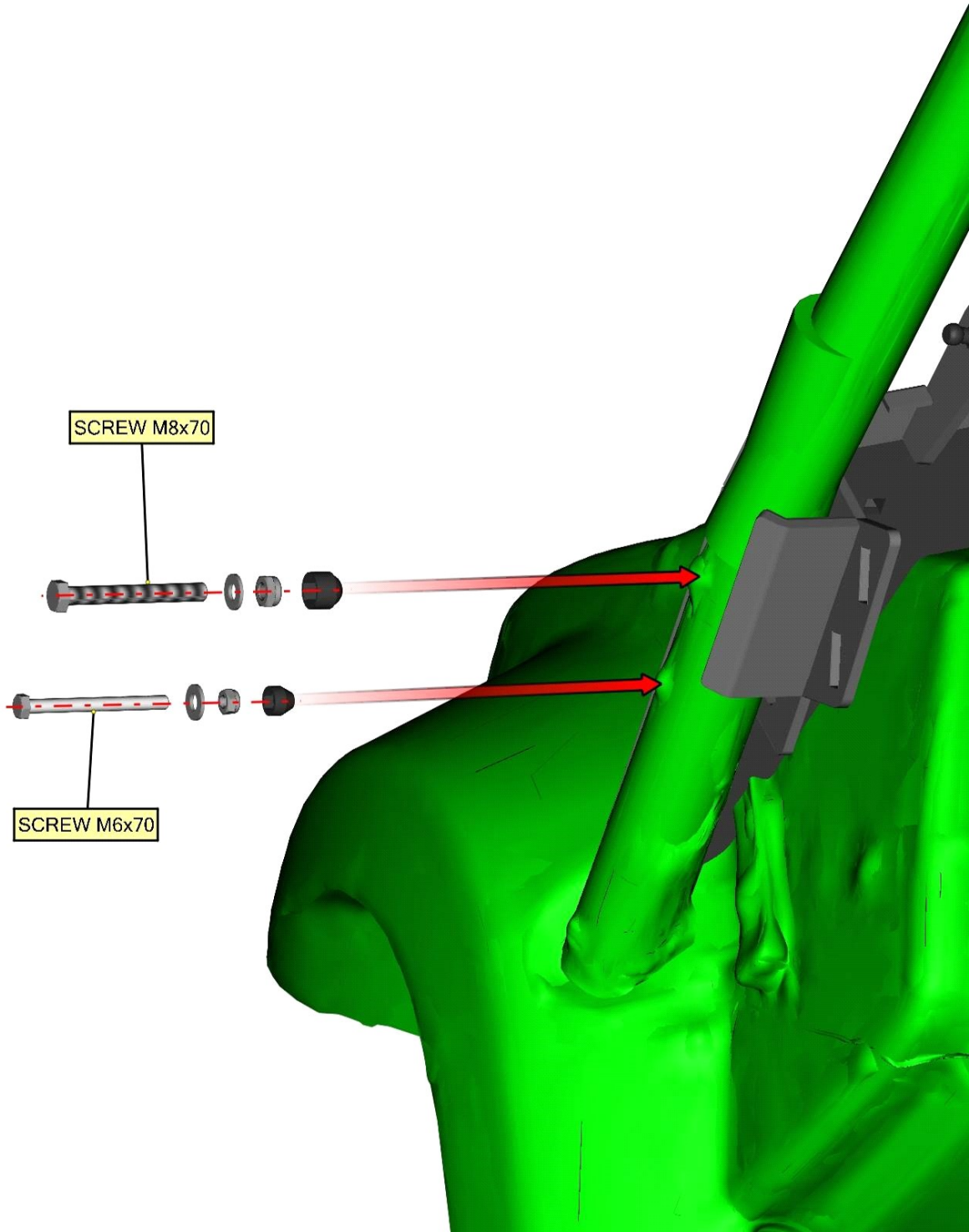

Attach the front bottom ledge holders with included fixing assemblies on both sides.

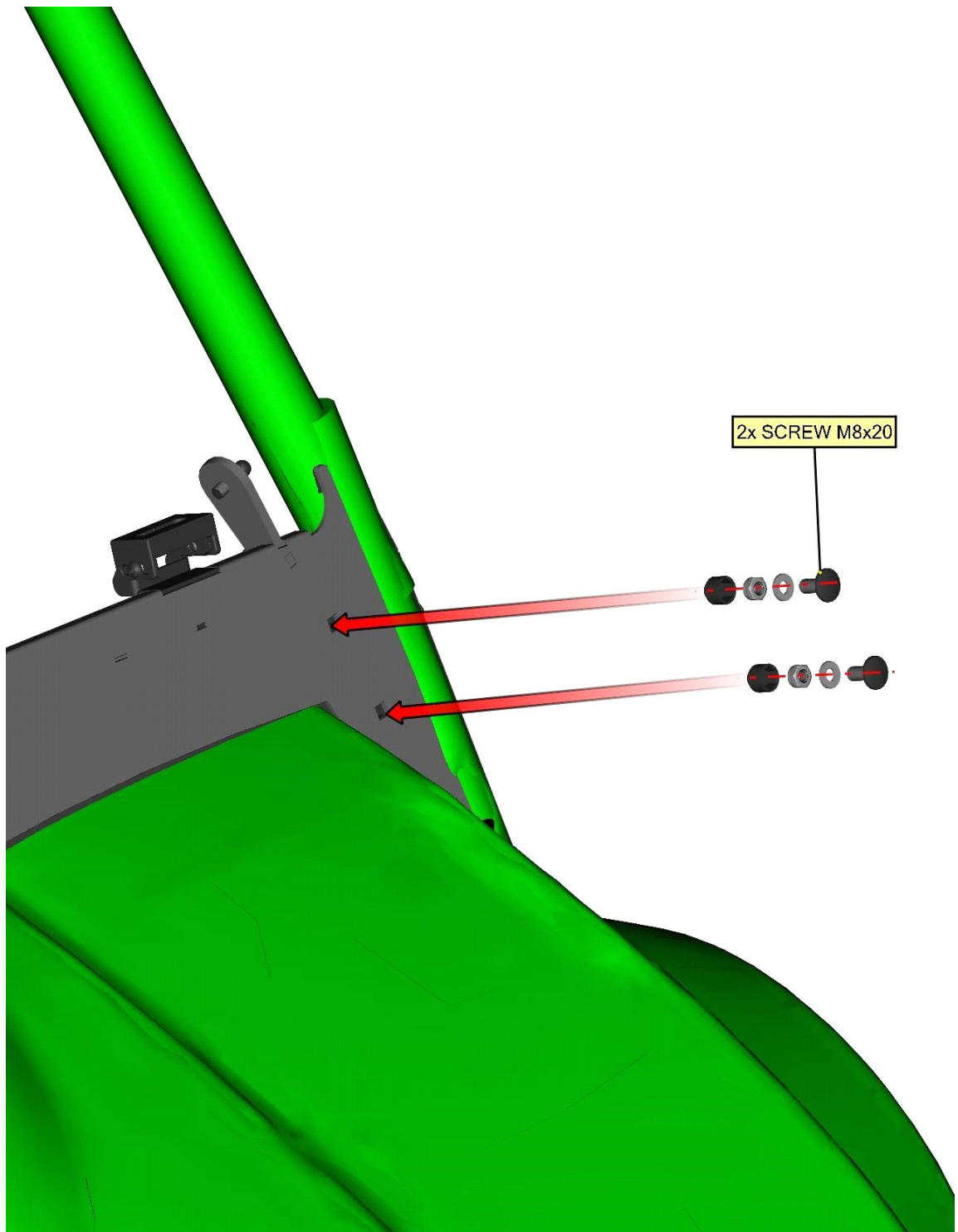

Place the front upper ledge onto the UTV frame.

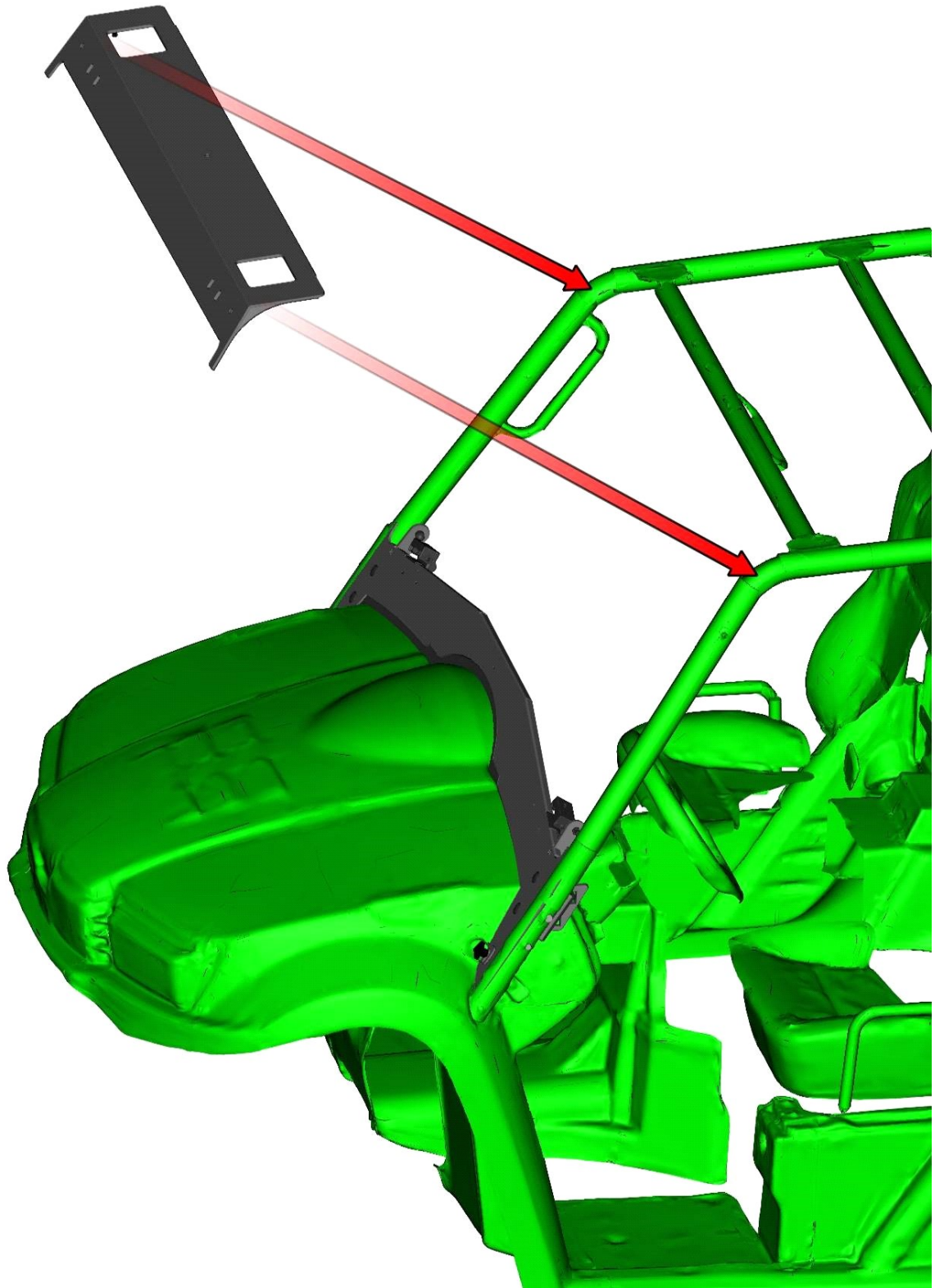

57

Place the front upper side holders onto the front upper ledge and the UTV frame.

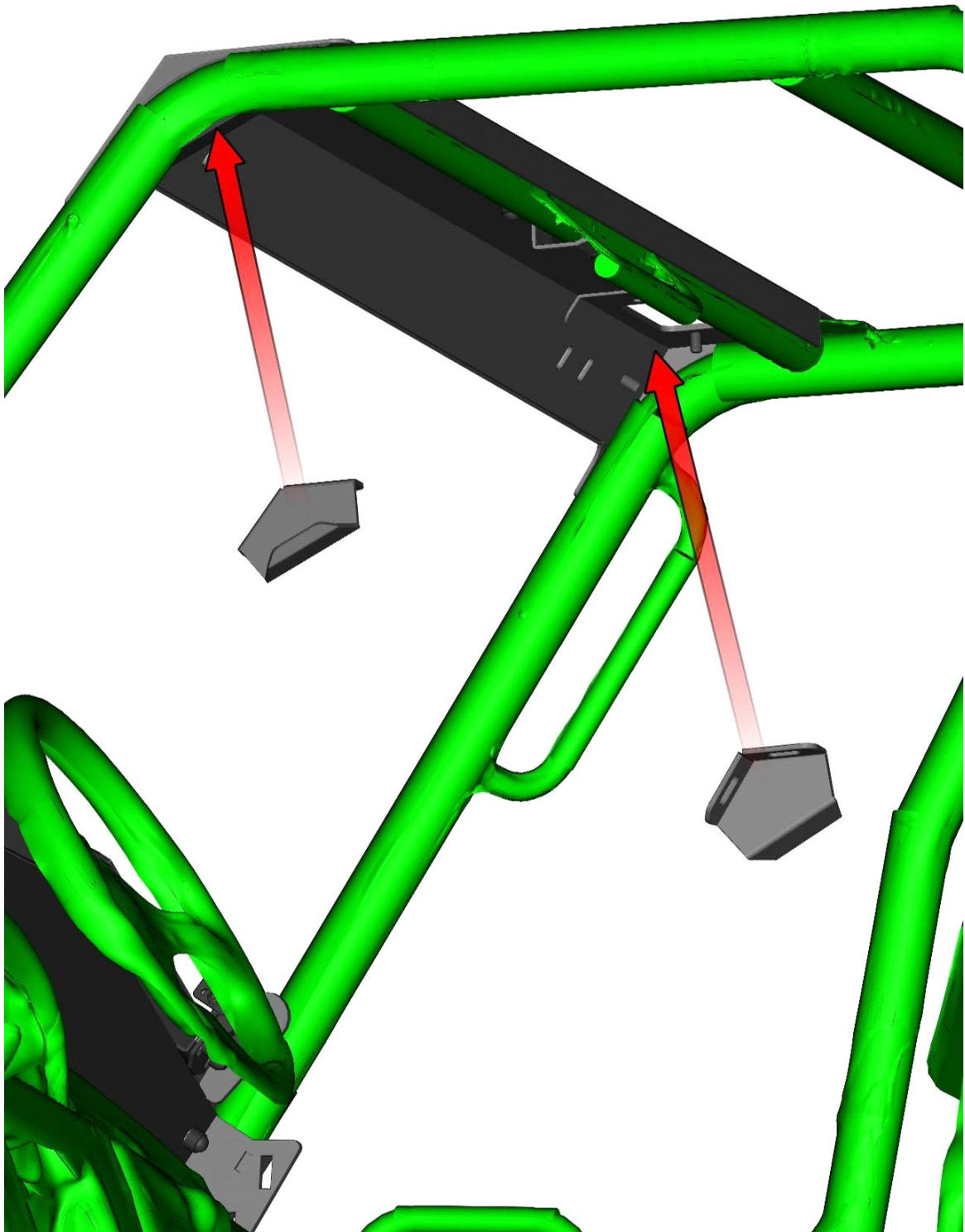

Attach the front upper ledge side holders with included fixing assemblies on both sides.

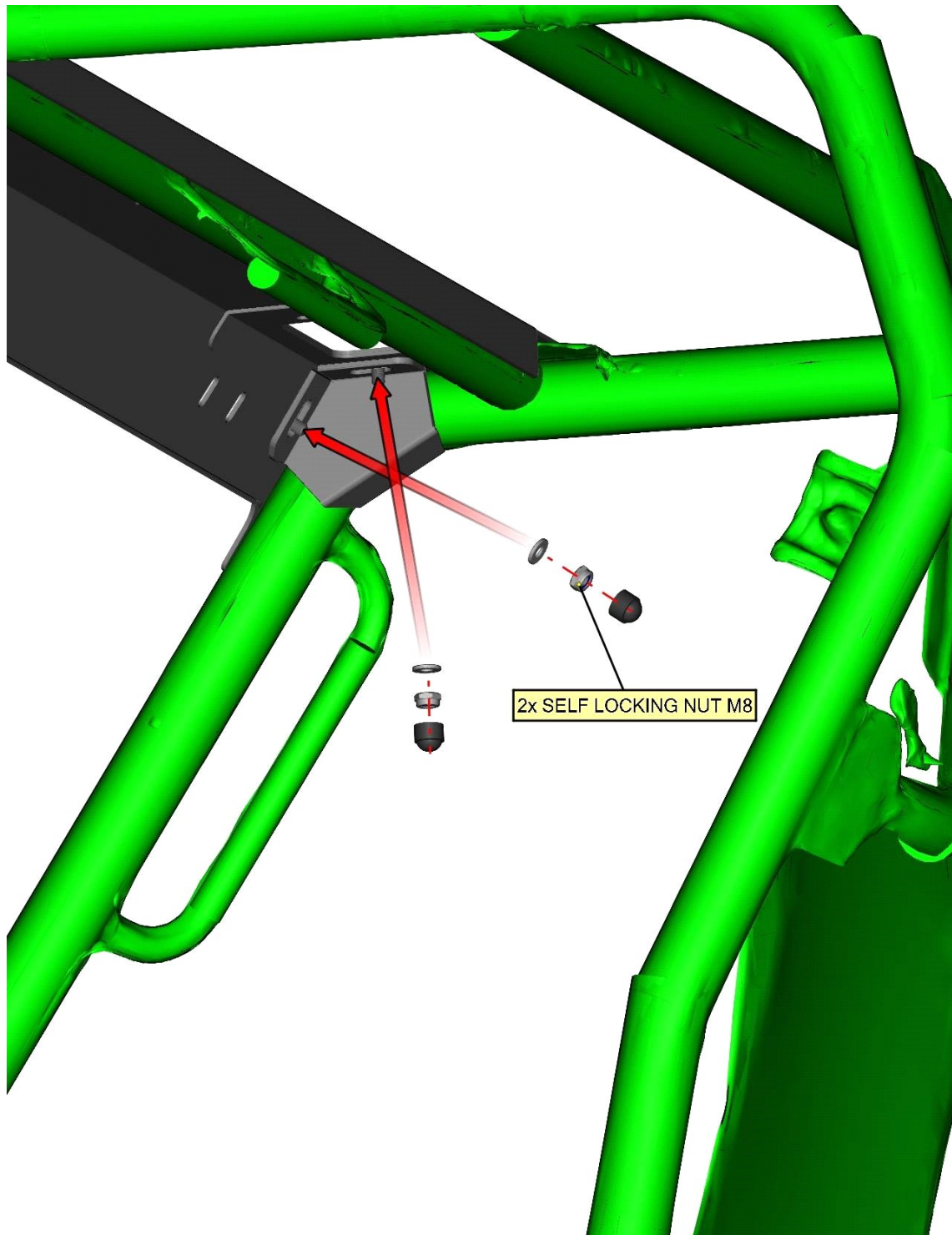

Mount the front upper ledge middle holder onto the front upper ledge with included fixing assembly.

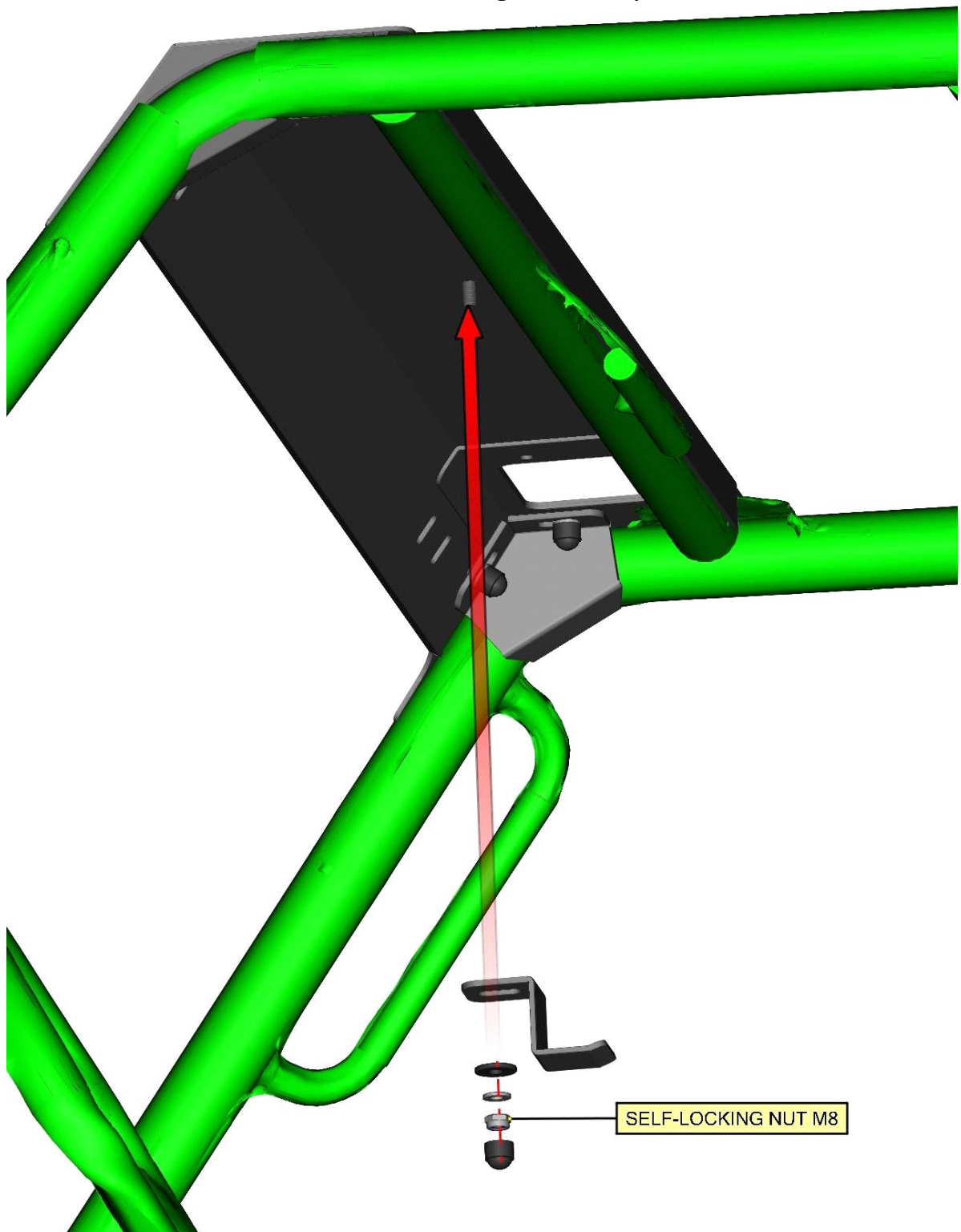

Place the front glass assembly onto the front bottom ledge and the front upper ledge in accordance with the holes.

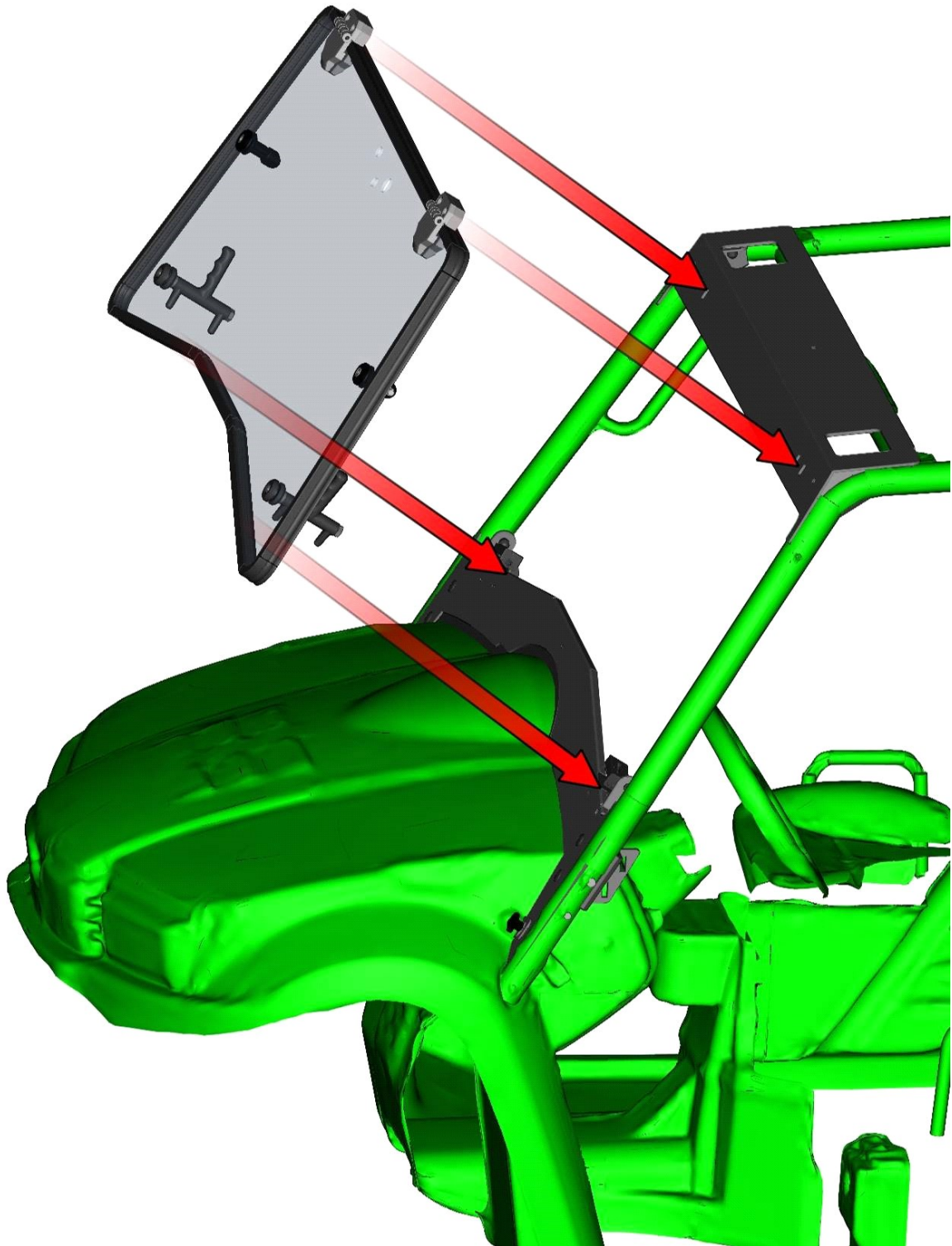

61

Adjust the front glass assembly to the best position.



62

Attach the front glass assembly with included fixing assemblies.

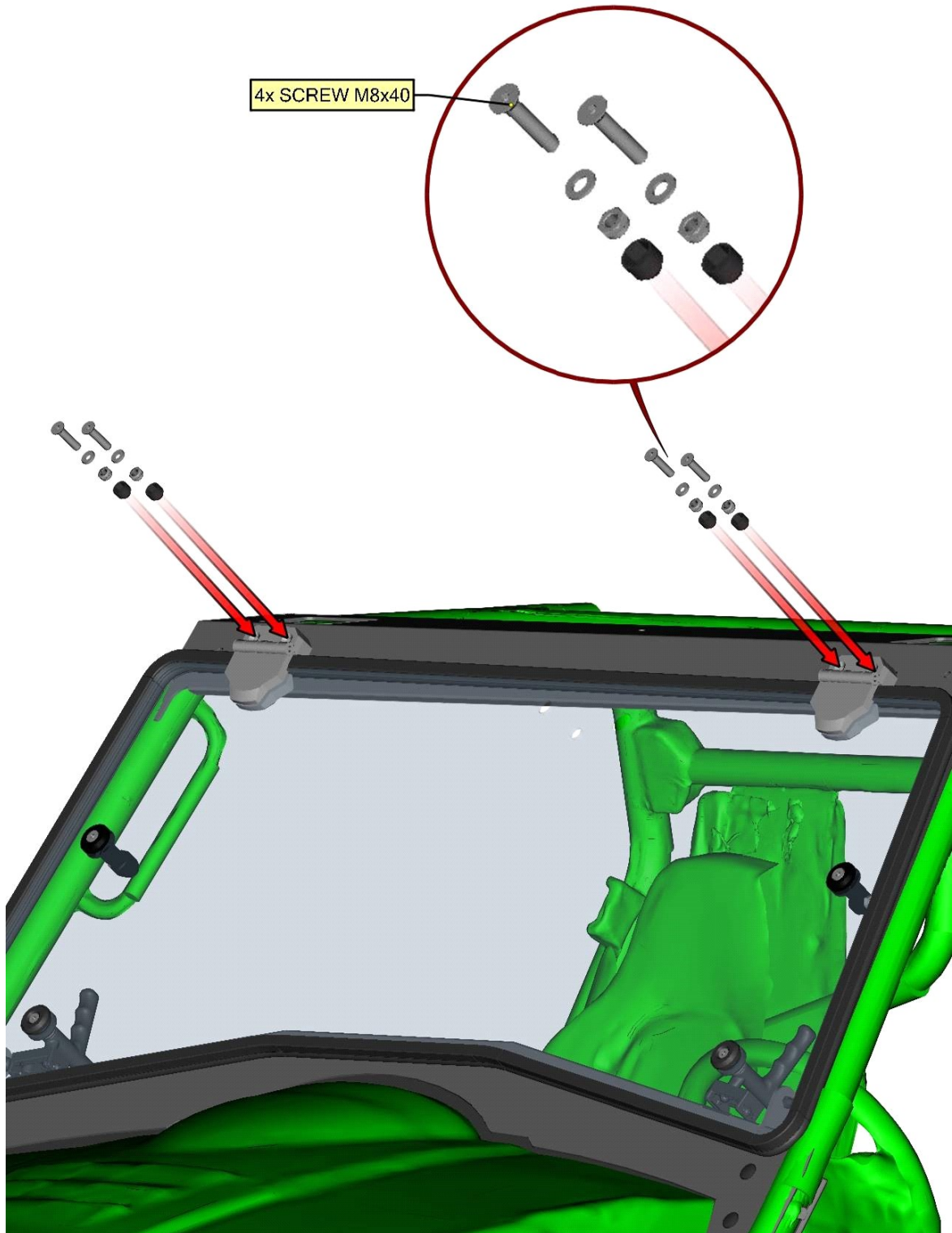

Install the front panel gas spring onto the gas spring holders on both sides of the windshield.

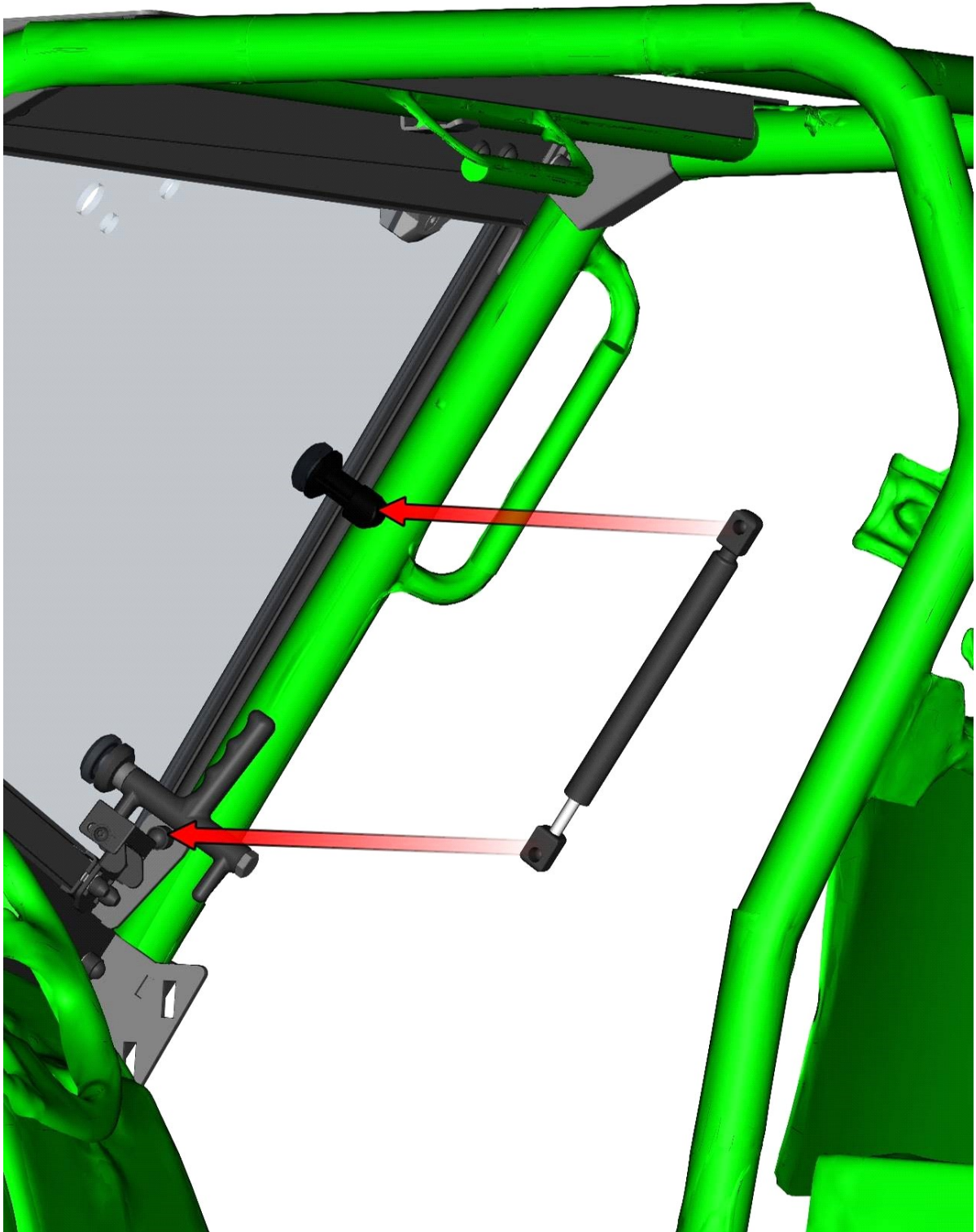

64

Place the front wiper motor onto the windshield inner side in accordance with the holes.

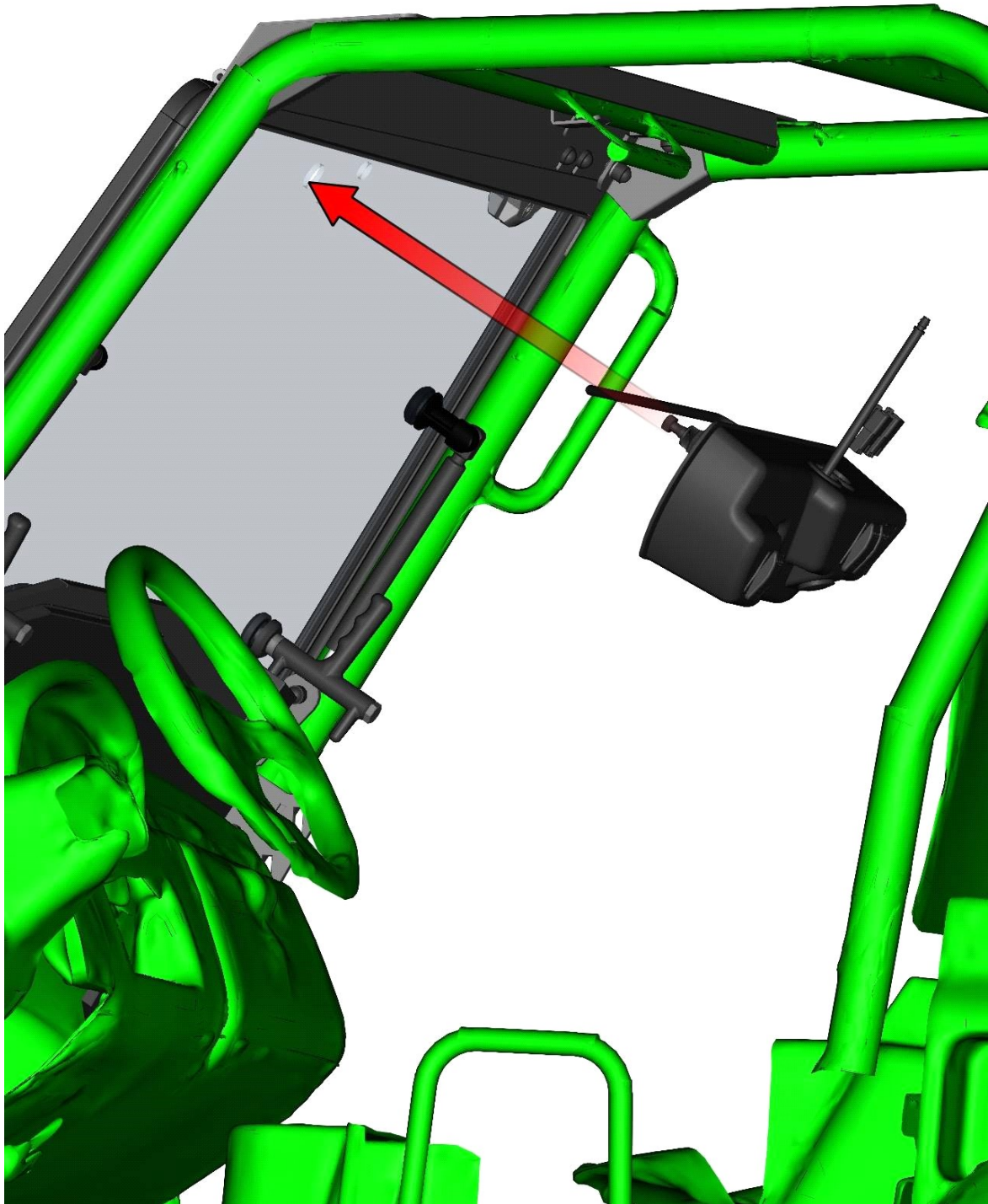

65

Mount the wiper arm and the wiper blade onto the wiper shaft.

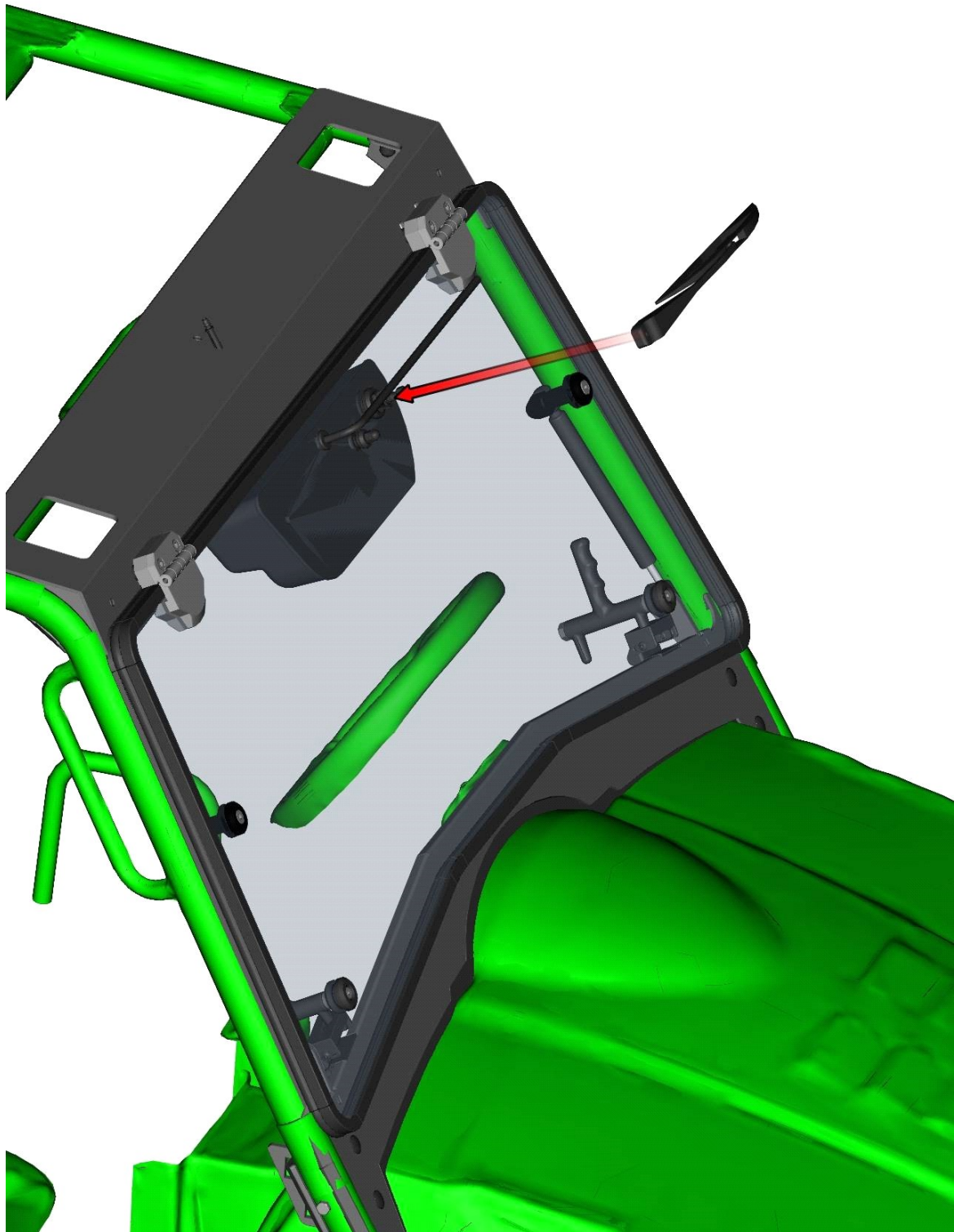

66

Attach the plastic hood holders with included fixing assembly on both sides.
Use the original rubber bands fixing points.

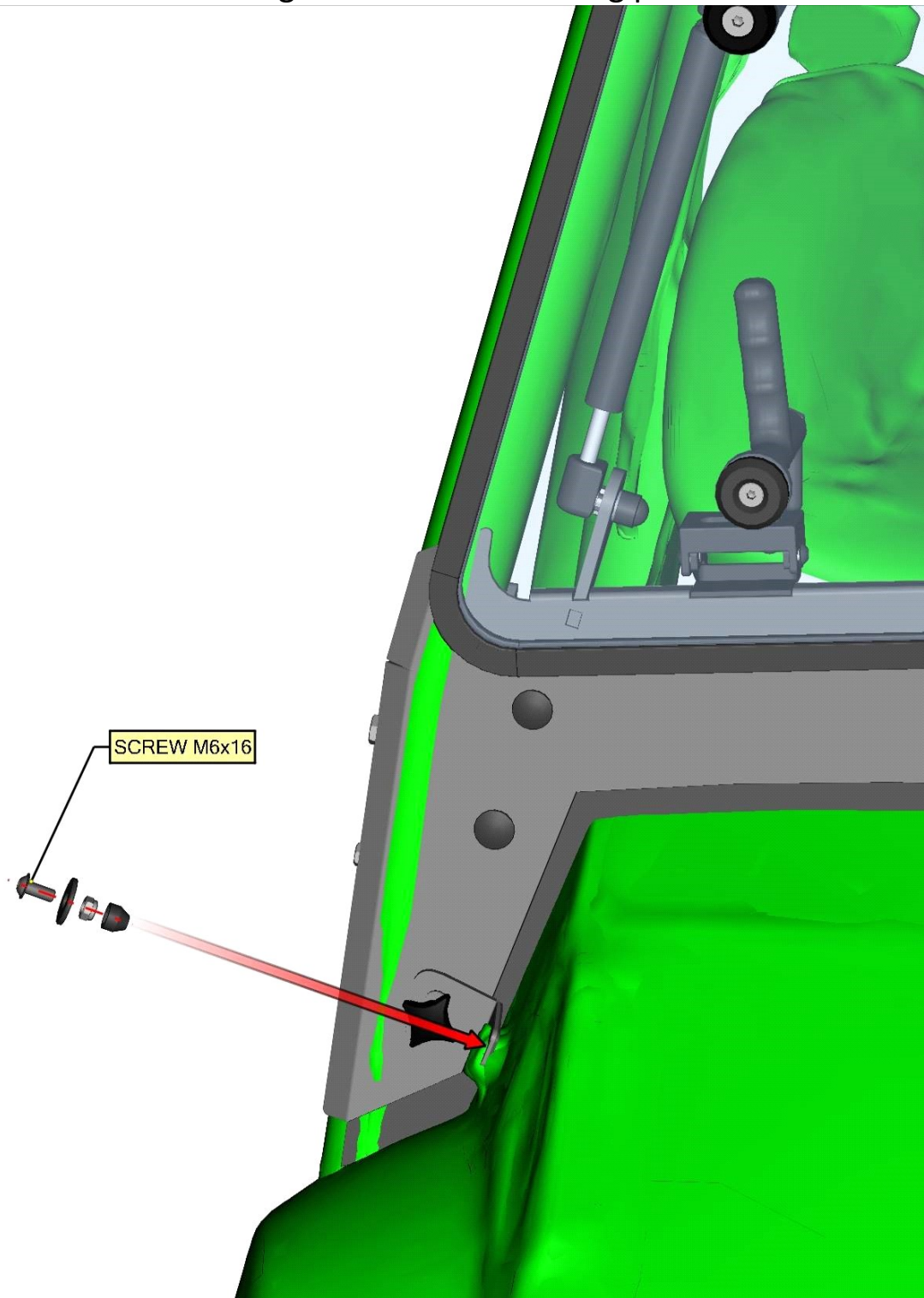

67

REAR PANEL

Place the left door base assembly onto the UTV frame.

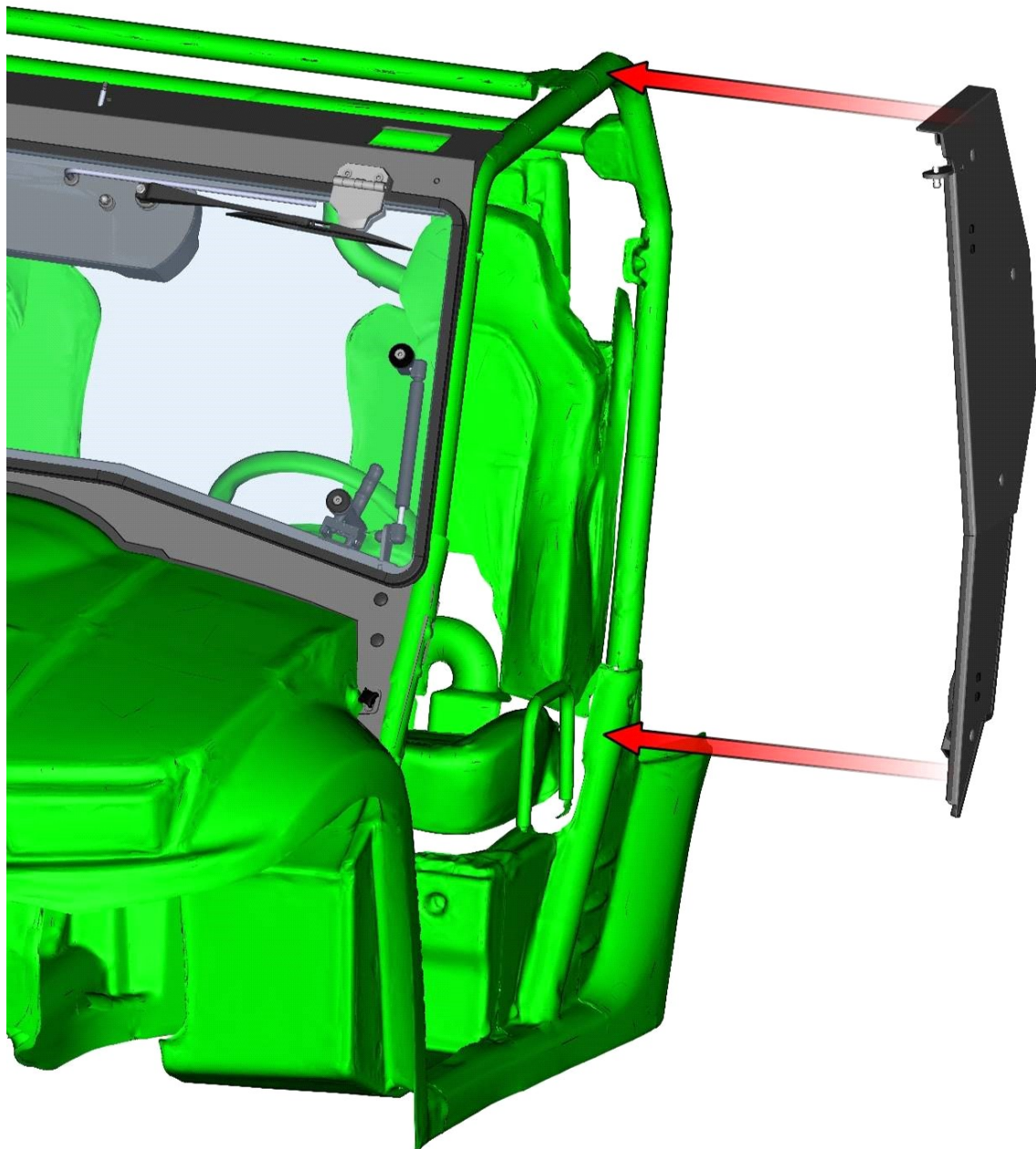

68

Adjust the left door base assembly to the best position.

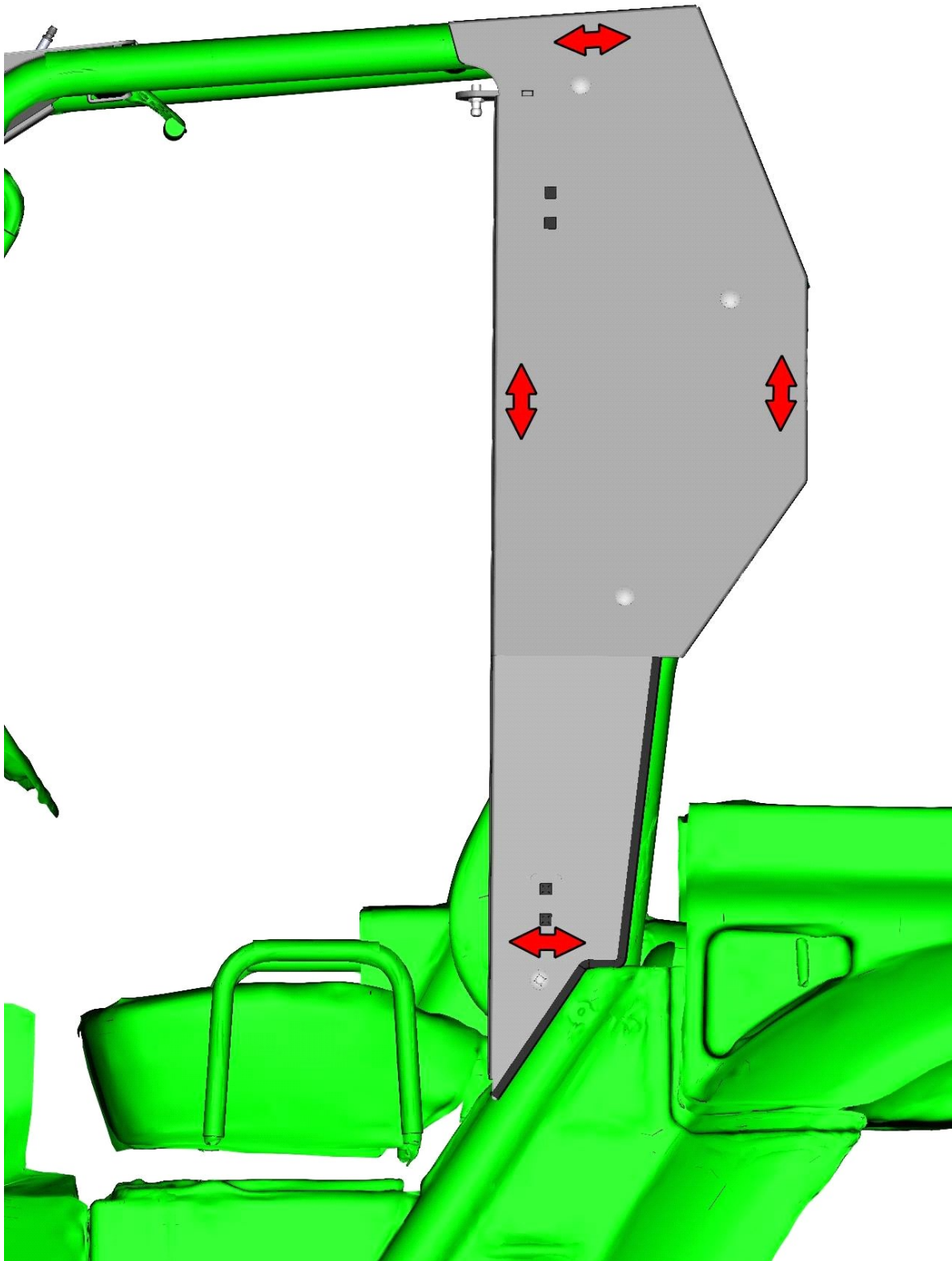

69

Turn the left door base holders to the correct position and tighten the clamping levers.

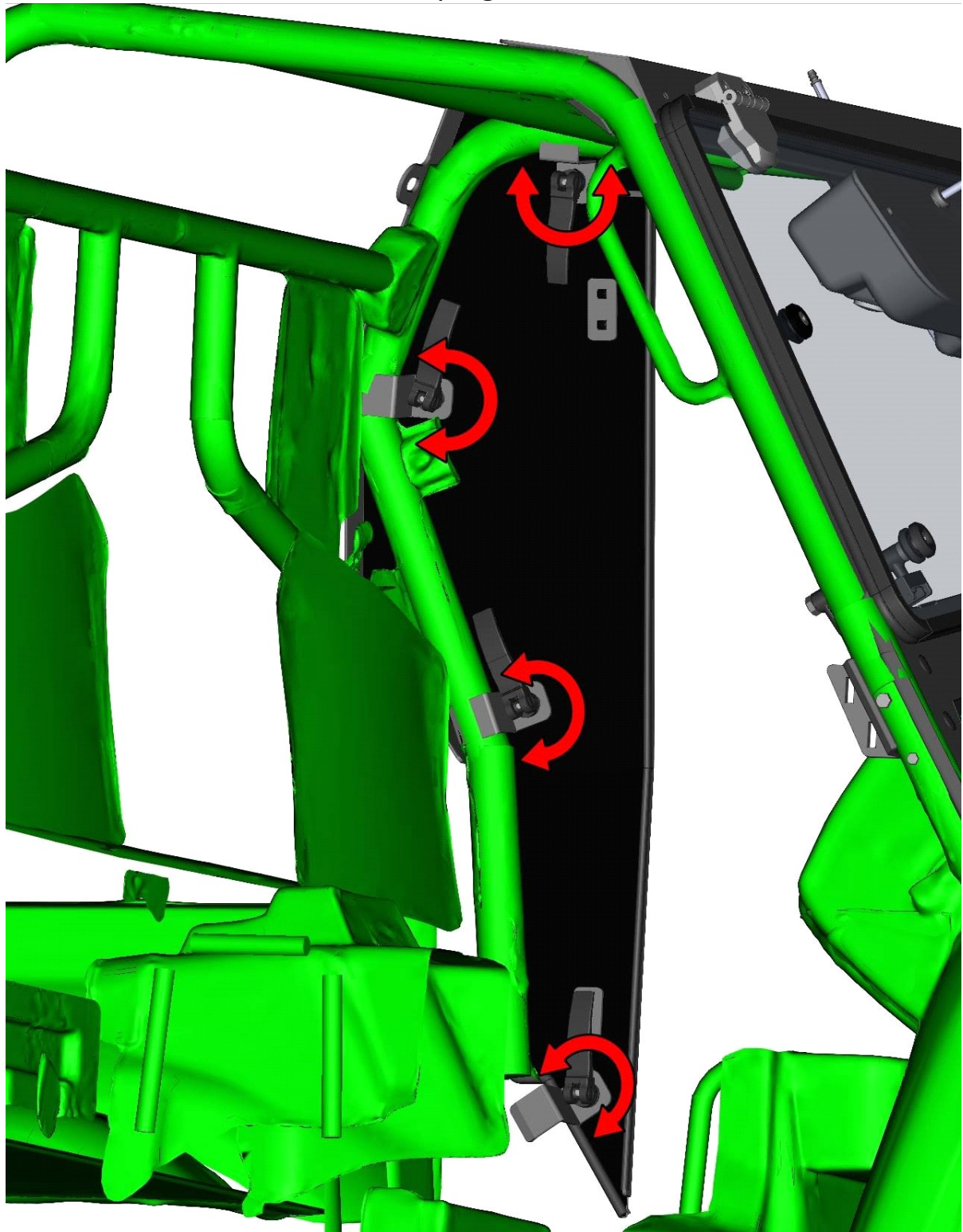

70

Repeat the previous steps with the right door base assembly.

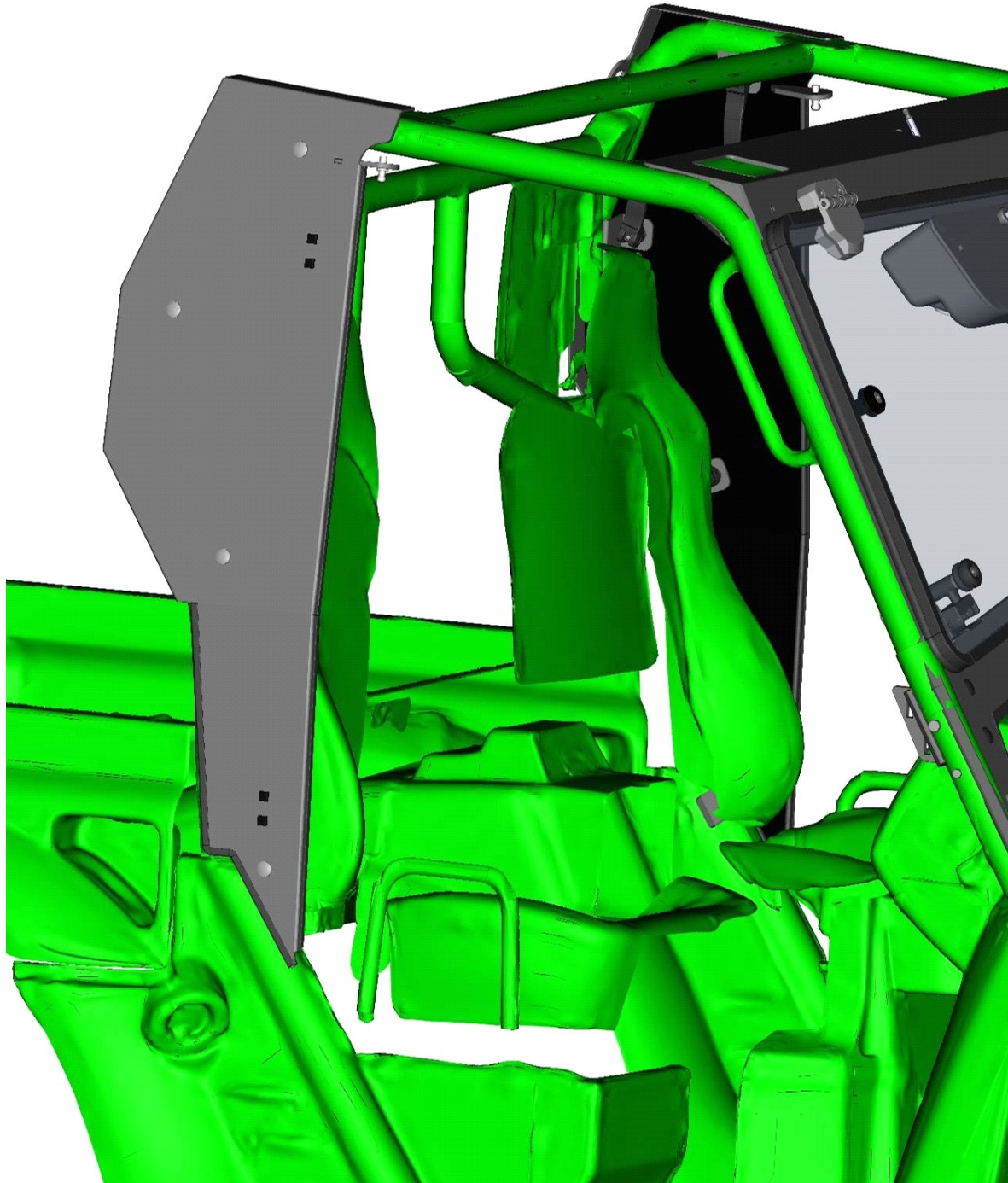

71

Place the bottom rear panel onto the UTV frame in accordance with the door bases holes.

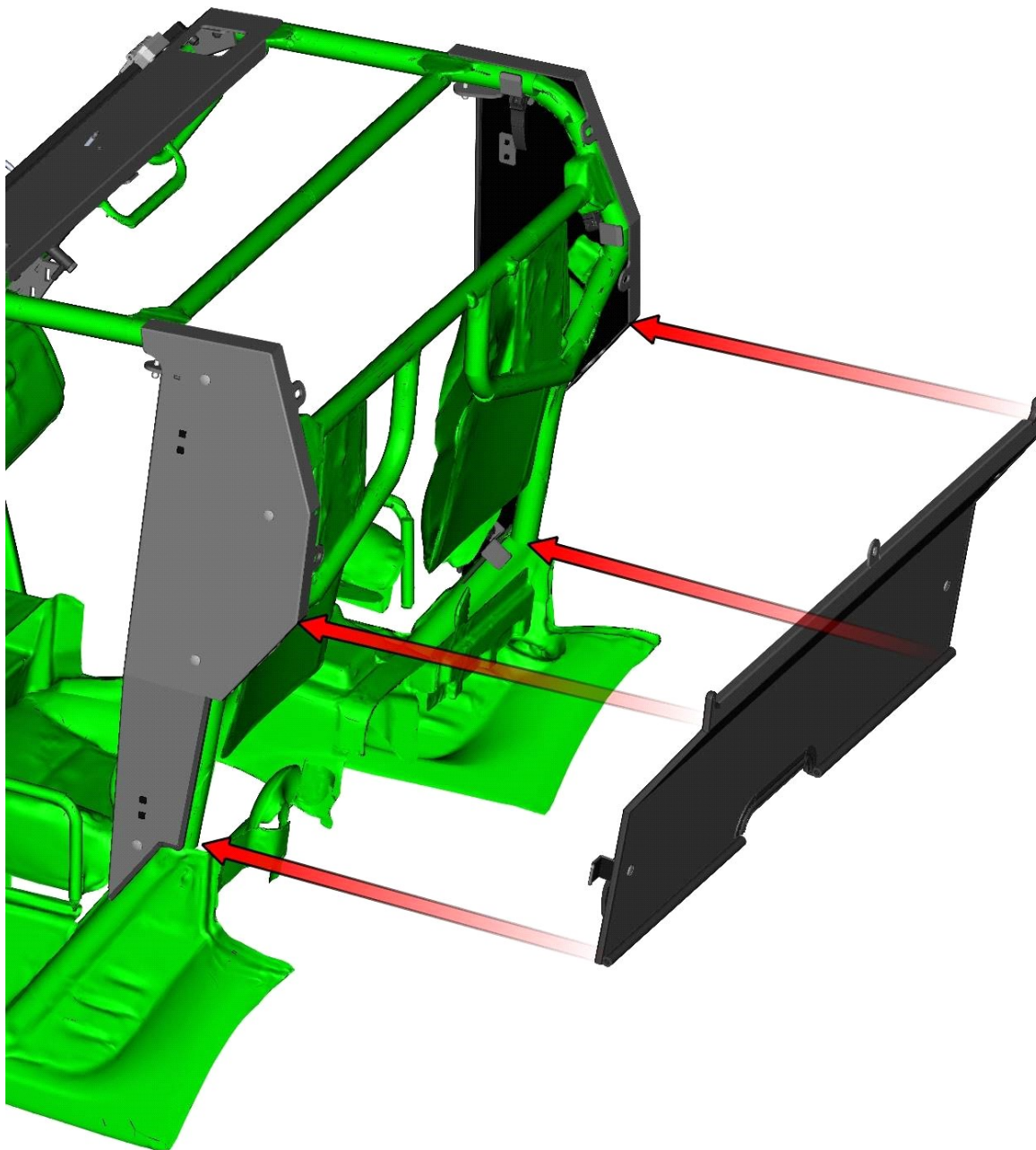

72

Adjust the bottom rear panel to the best position.

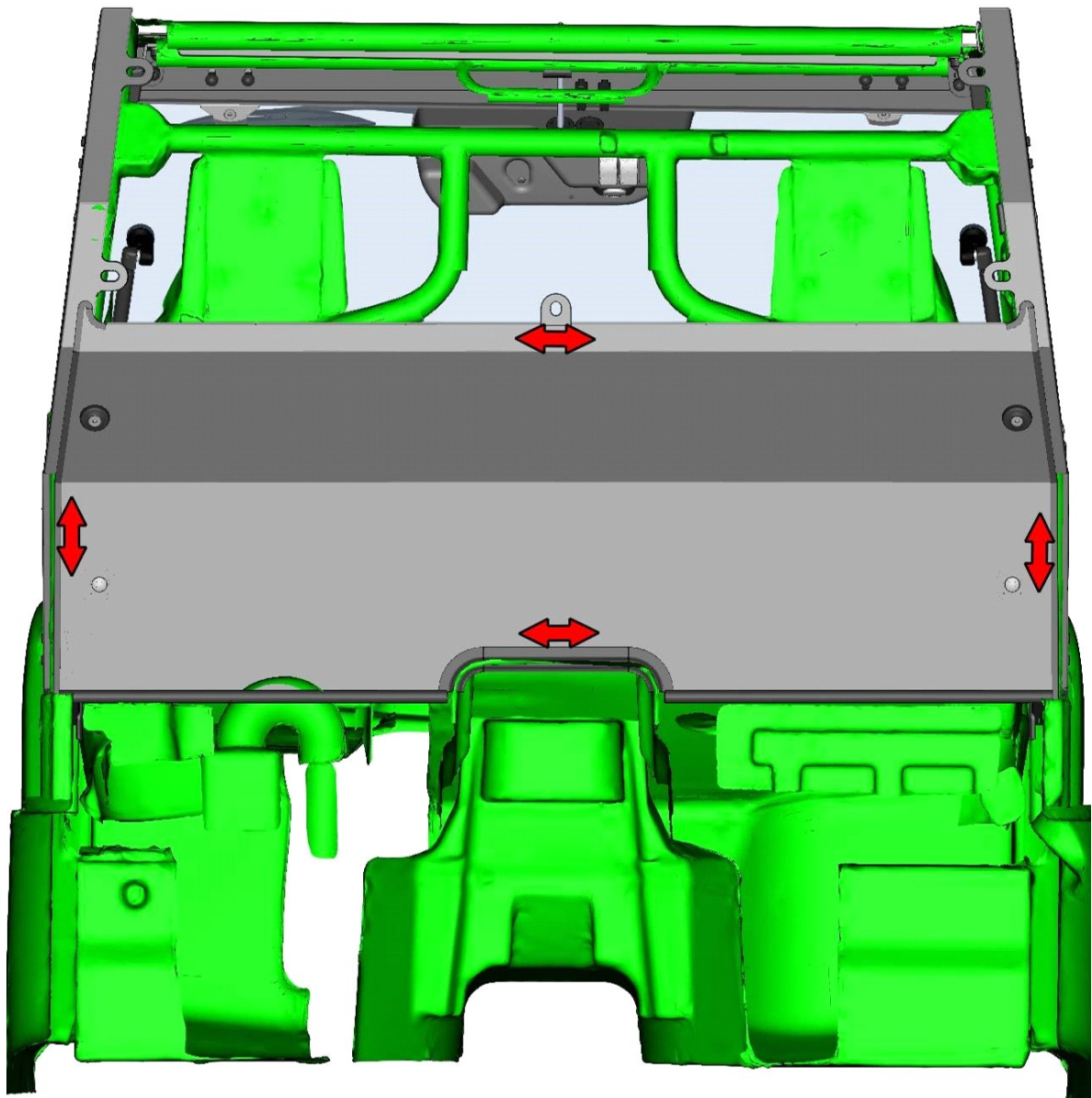

73

Turn the bottom rear panel holders to the correct position and tighten the clamping levers on both sides.

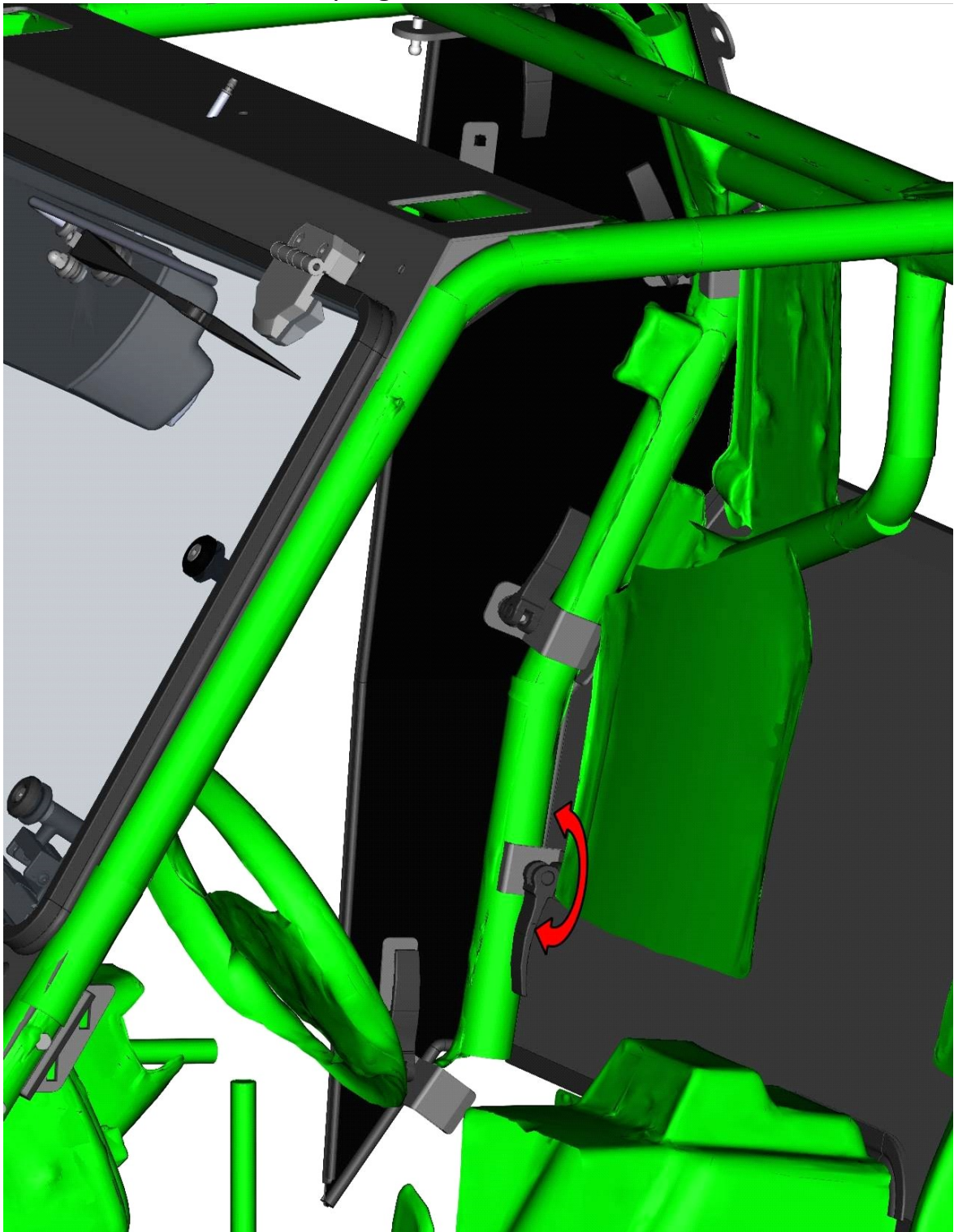

Attach the bottom rear panel with included fixing assemblies.

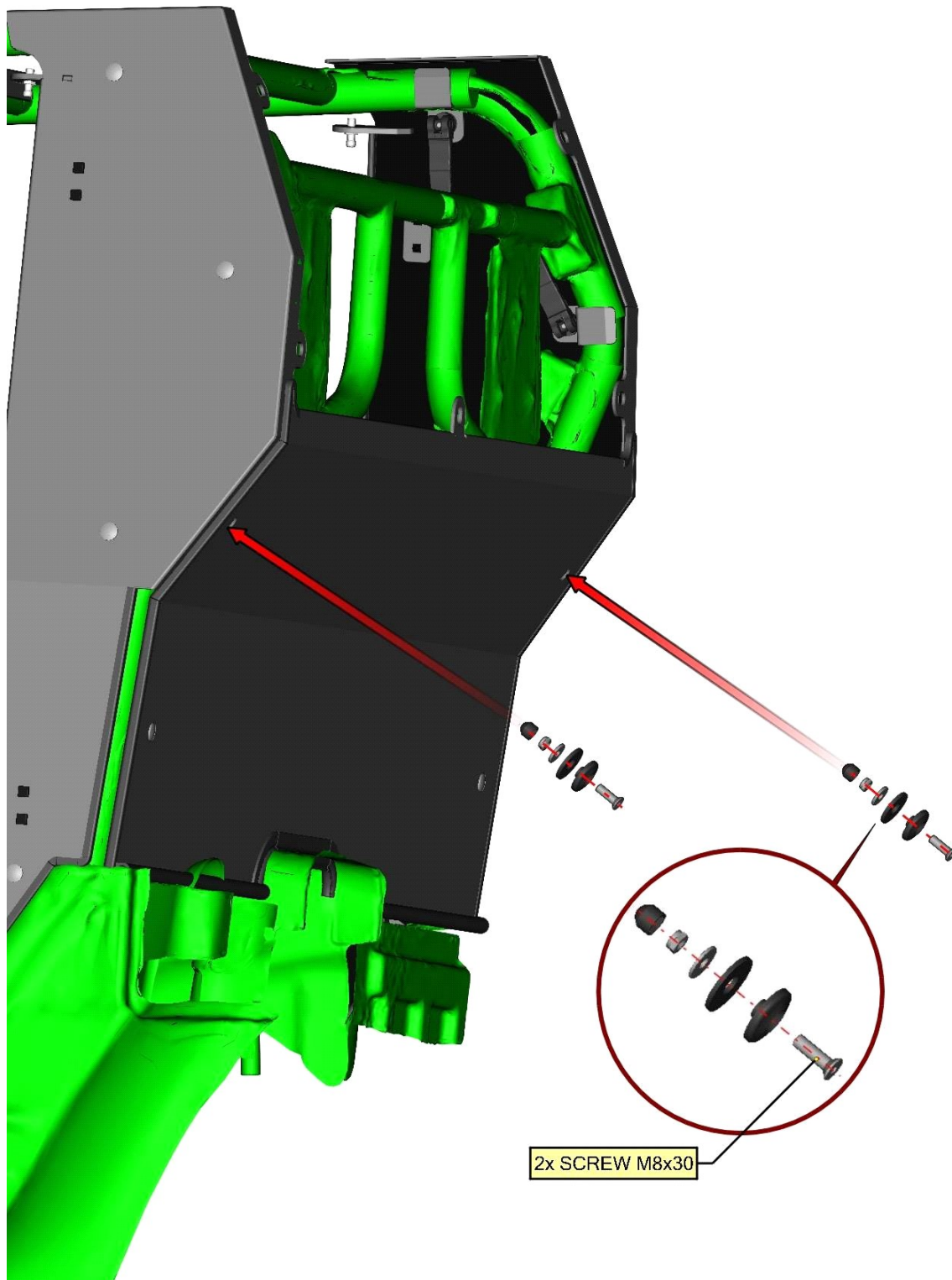

75

Place the rear polycarbonate onto the bottom rear panel and the door bases.

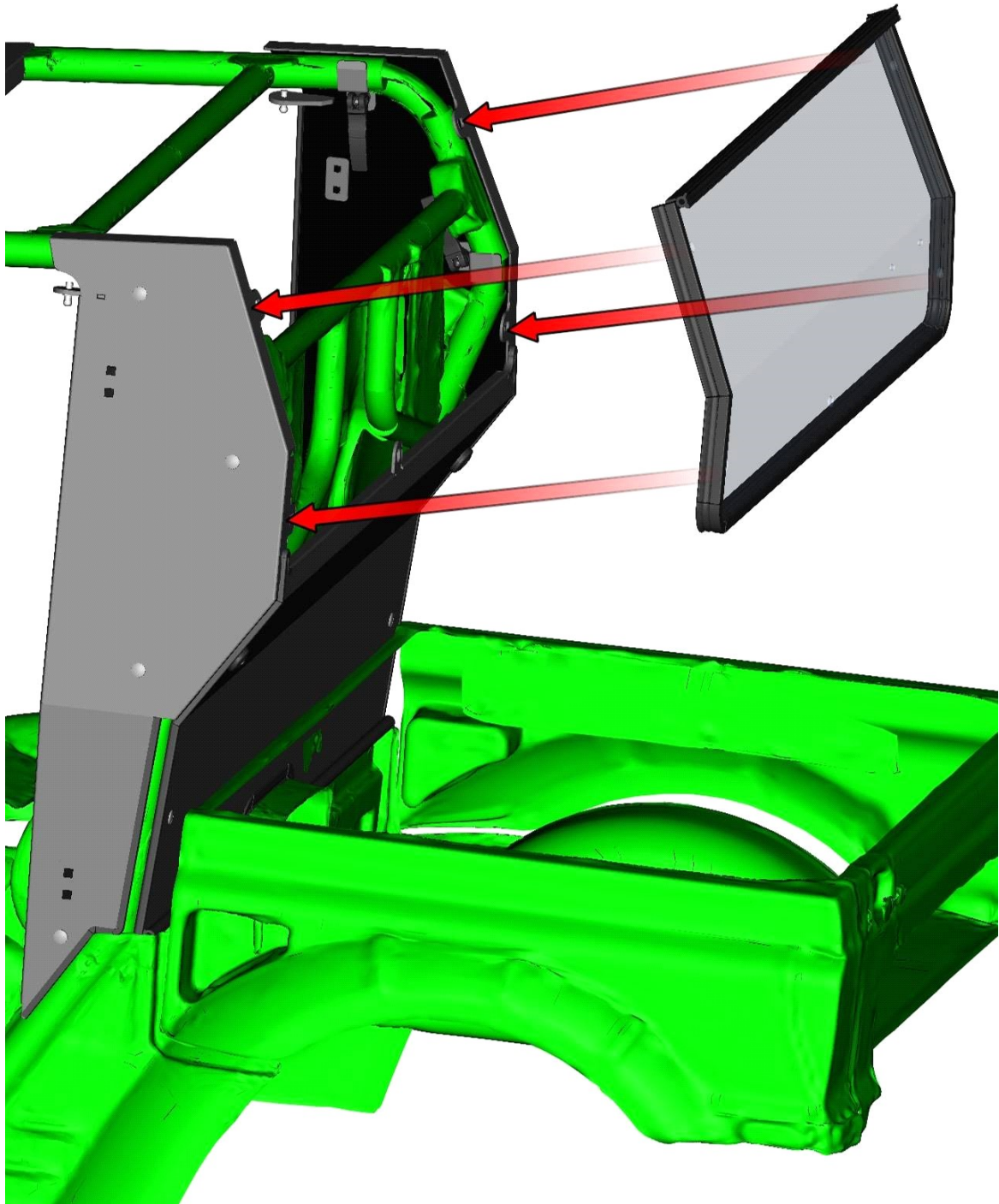

Adjust the rear polycarbonate to the best position in accordance with the holes.

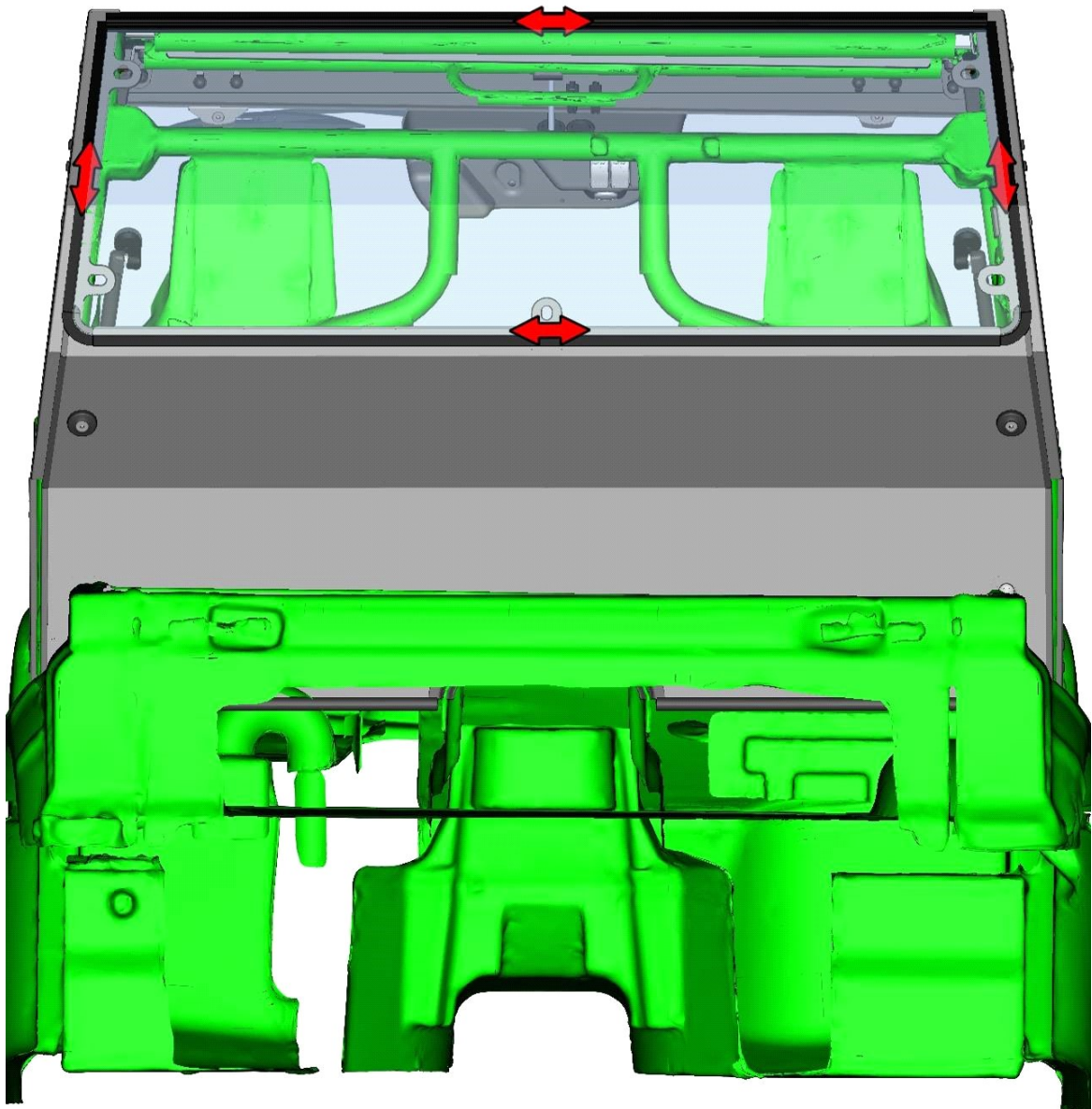

77

Attach the rear polycarbonate with included fixing assemblies.

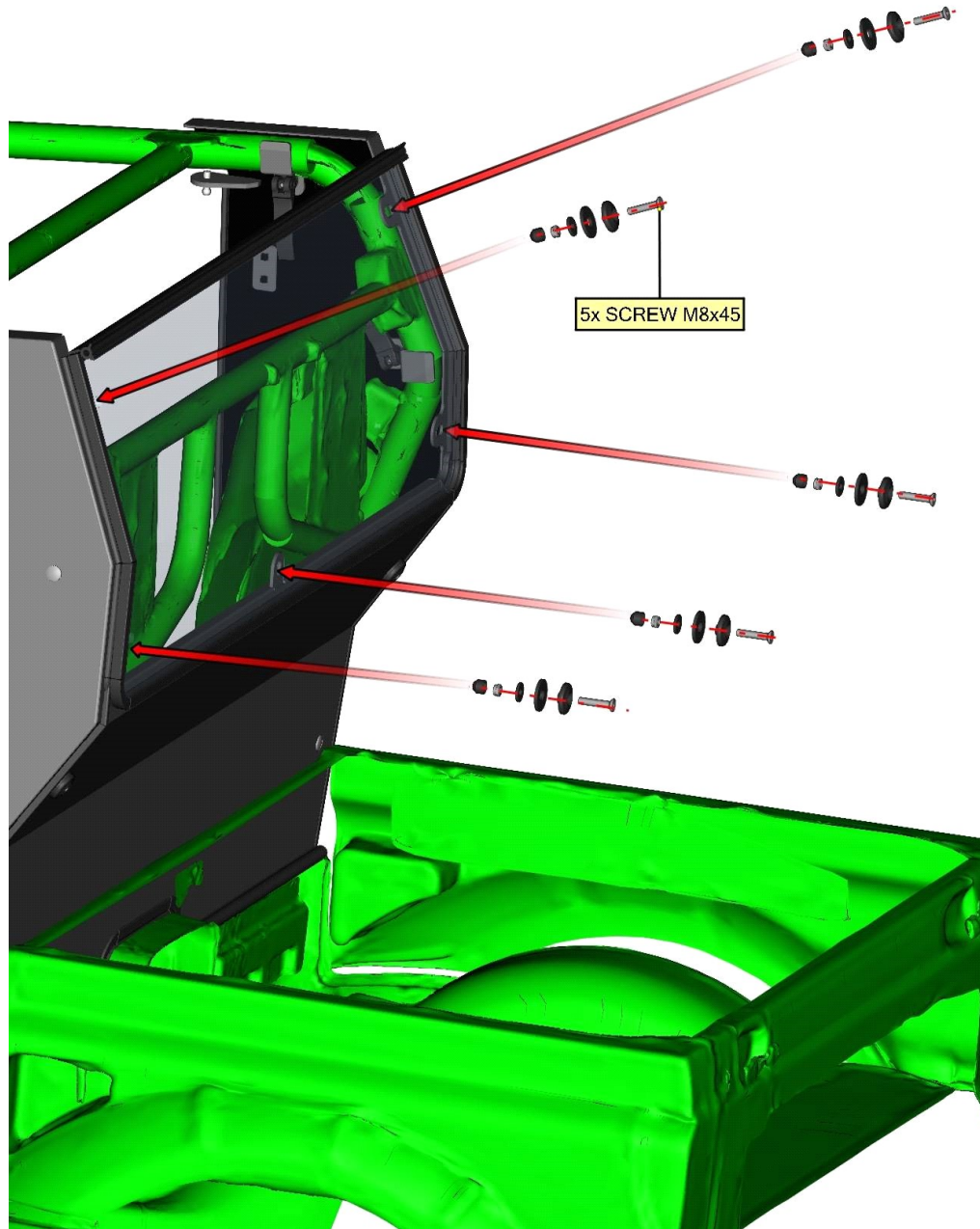

Place the roof panel onto the UTV frame.

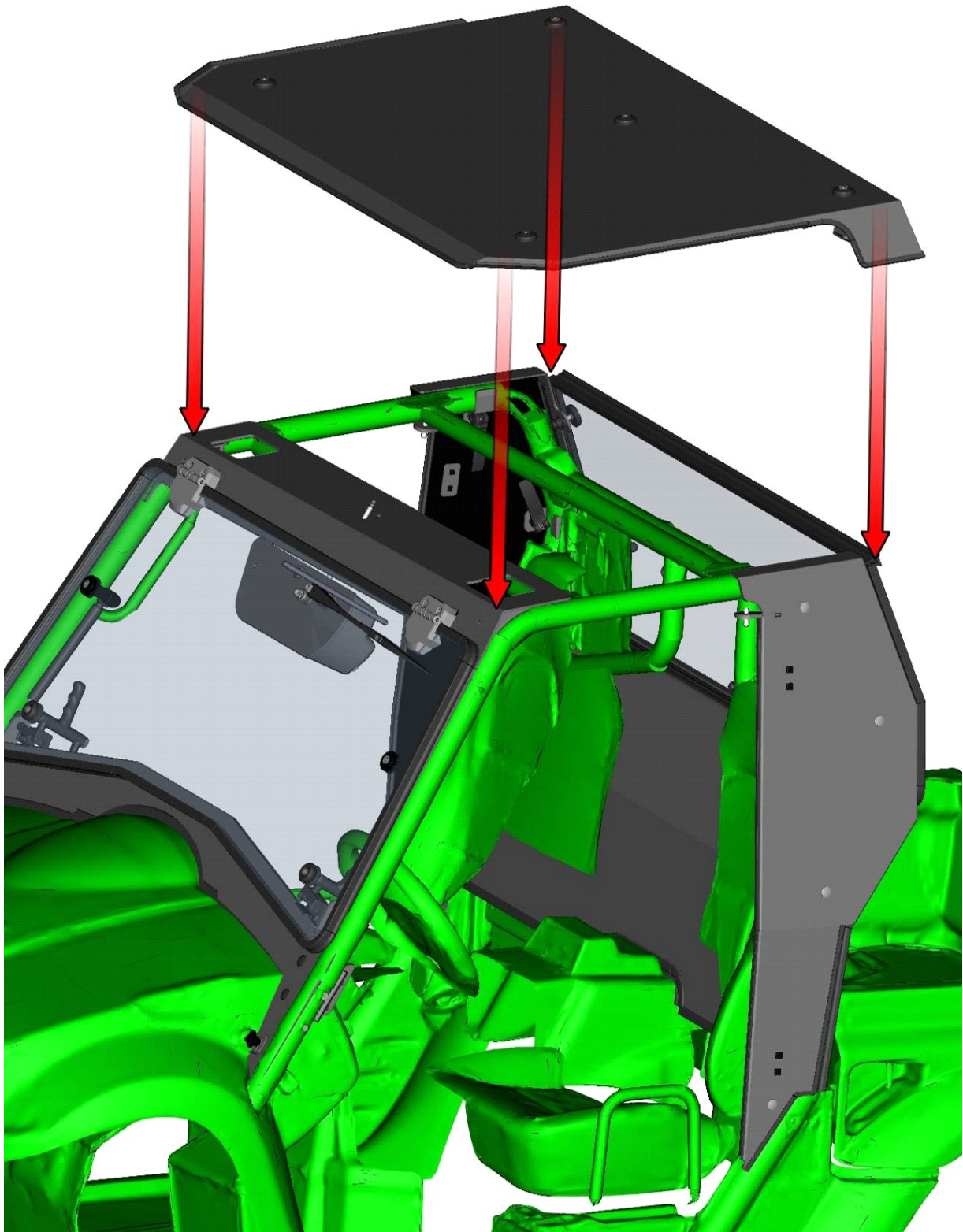

79

Adjust the roof panel to the best position.

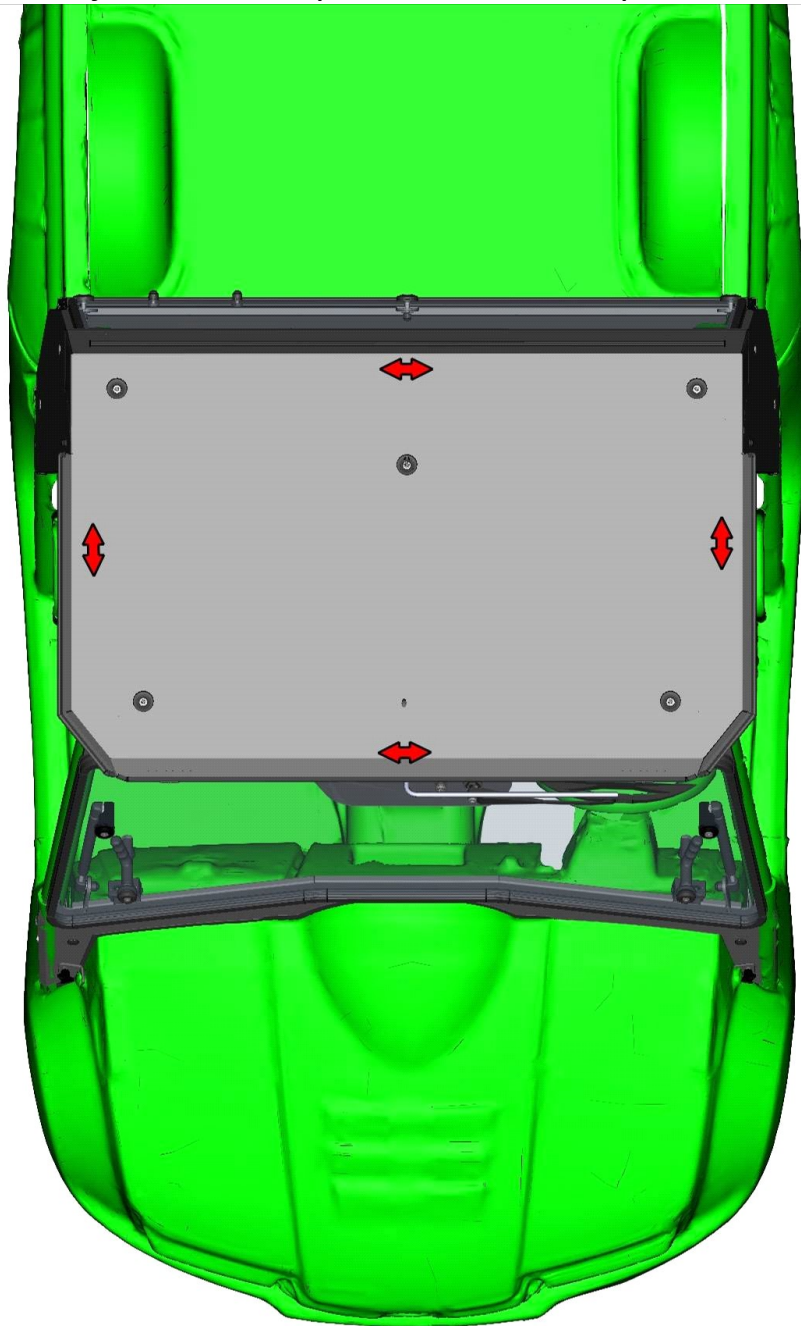

80

Turn the roof panel holders to the correct position and tighten the clamping levers on both sides of the roof.

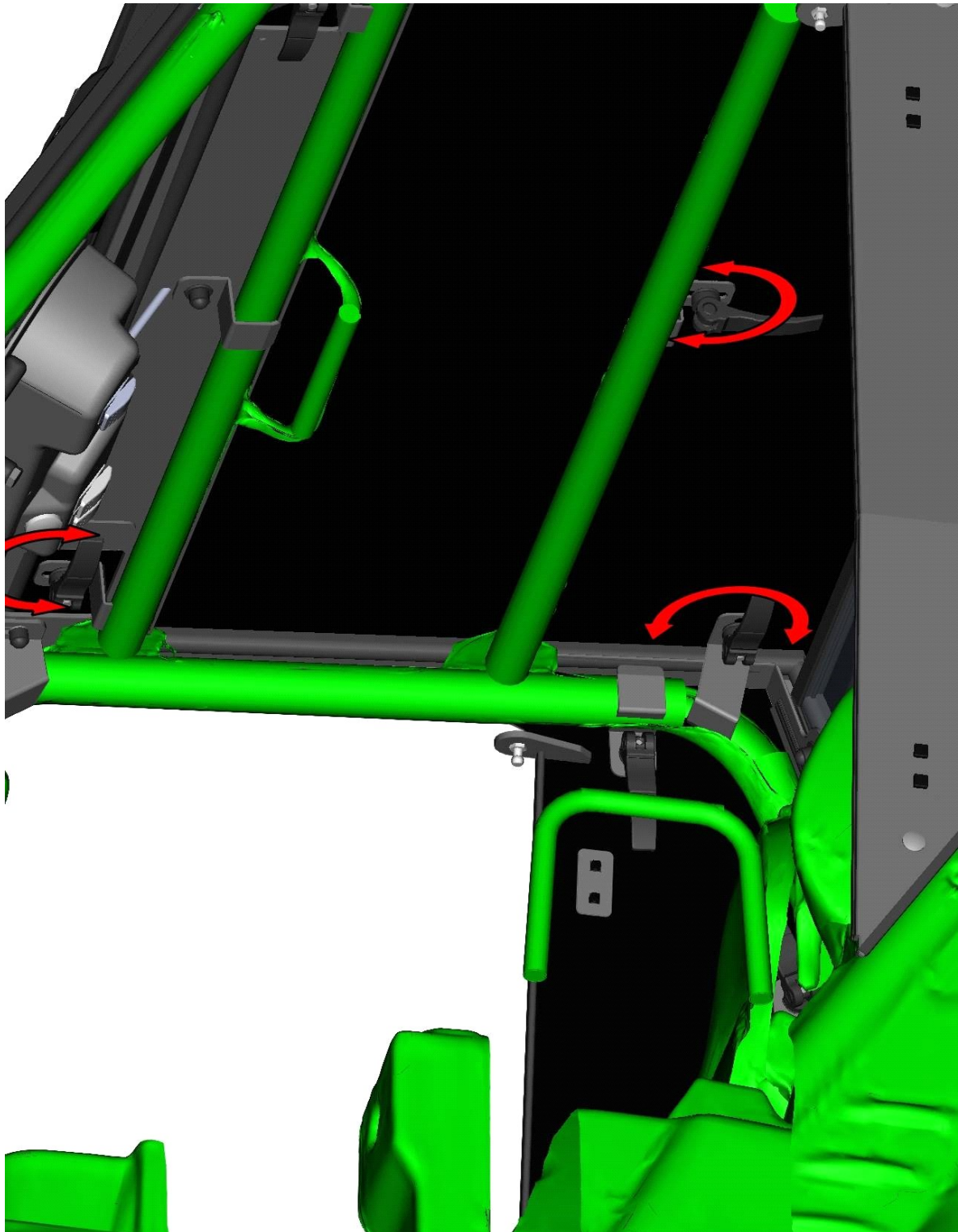

81

LEFT DOOR + RIGHT DOOR

Remove the plastic square covers front the left door base.

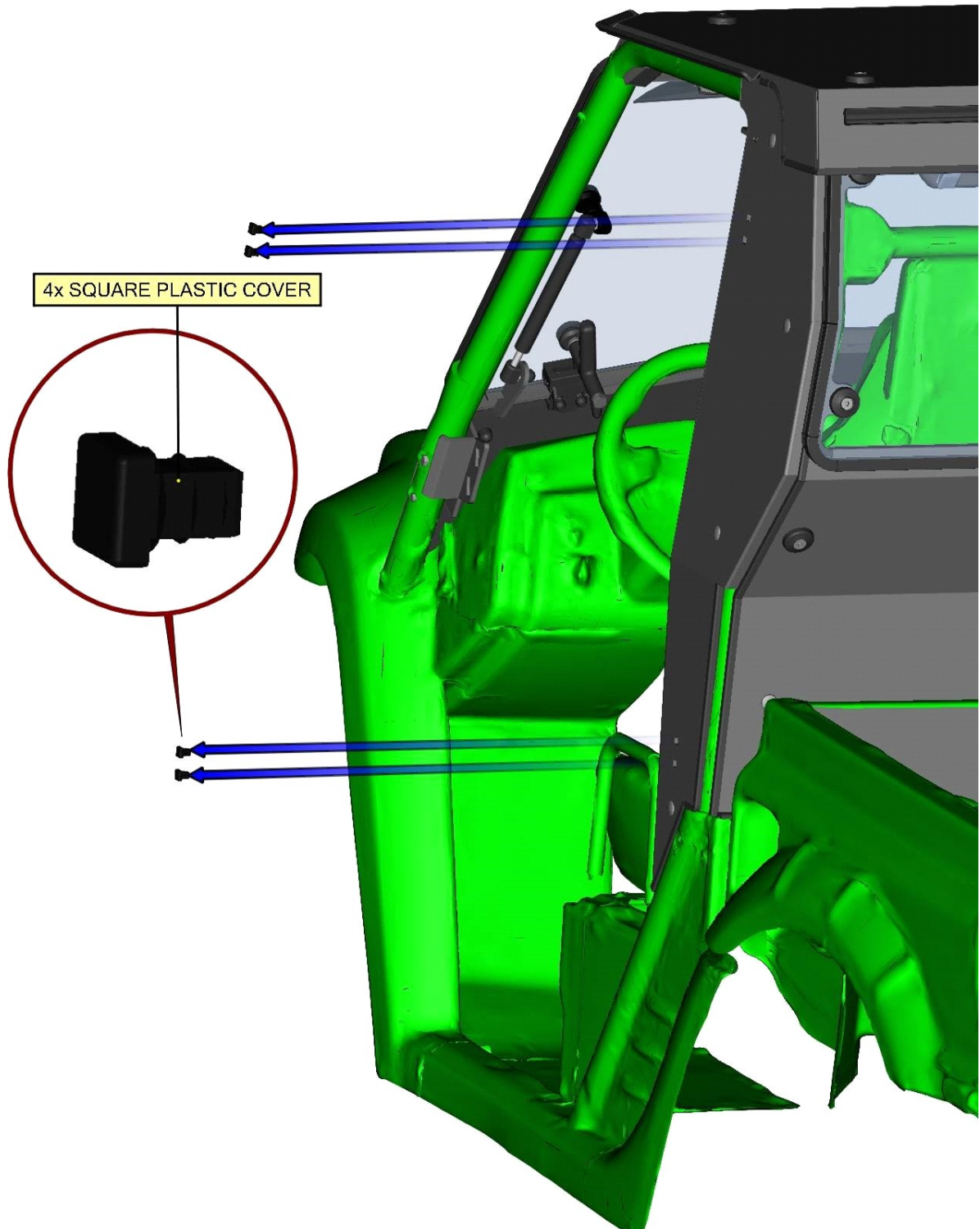

Difference between upper and bottom hinge.

UPPER HINGE



BOTTOM HINGE



Place the left door hinges onto the left door base in accordance with the holes.

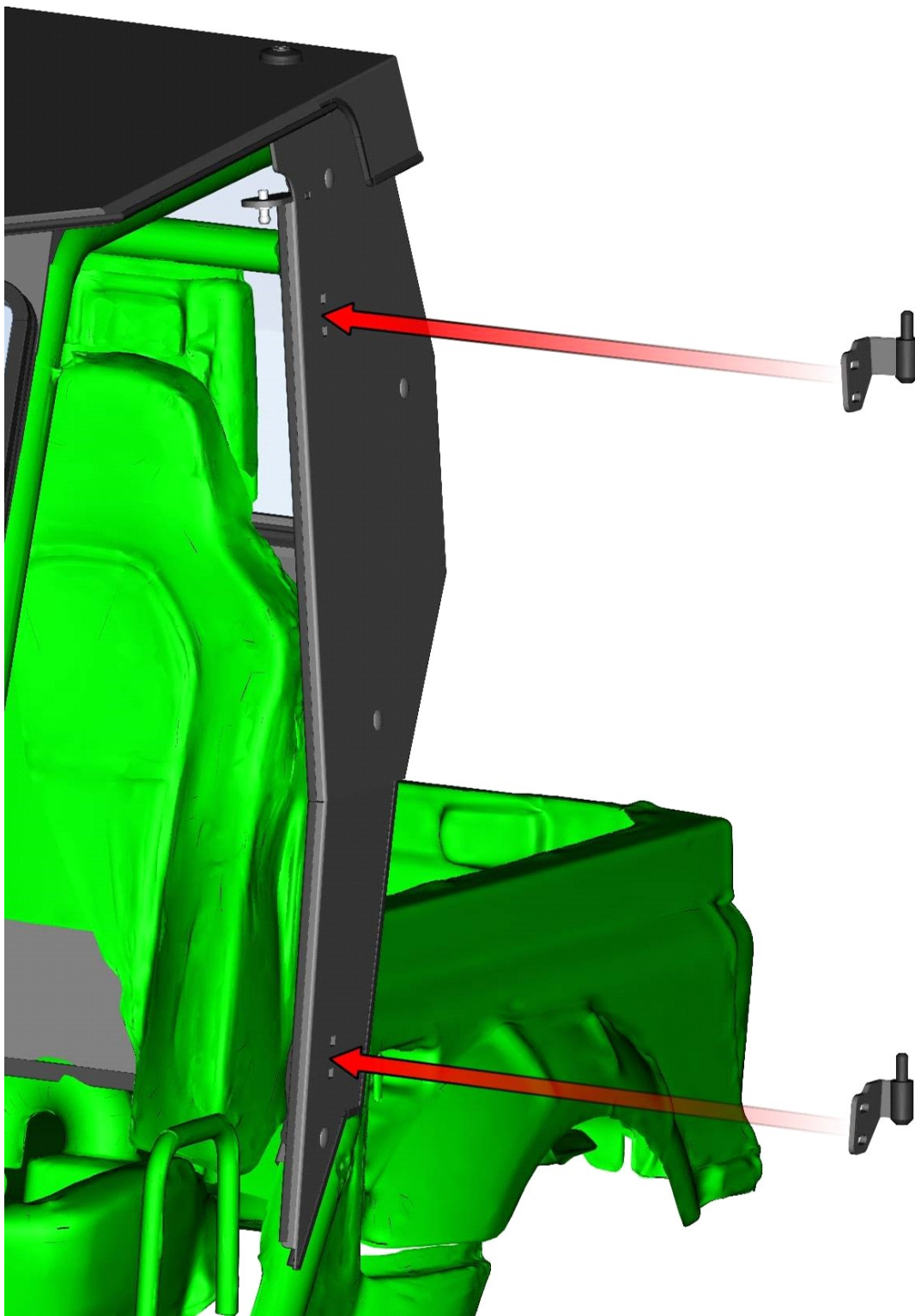

Attach the left door hinges with included fixing assemblies.

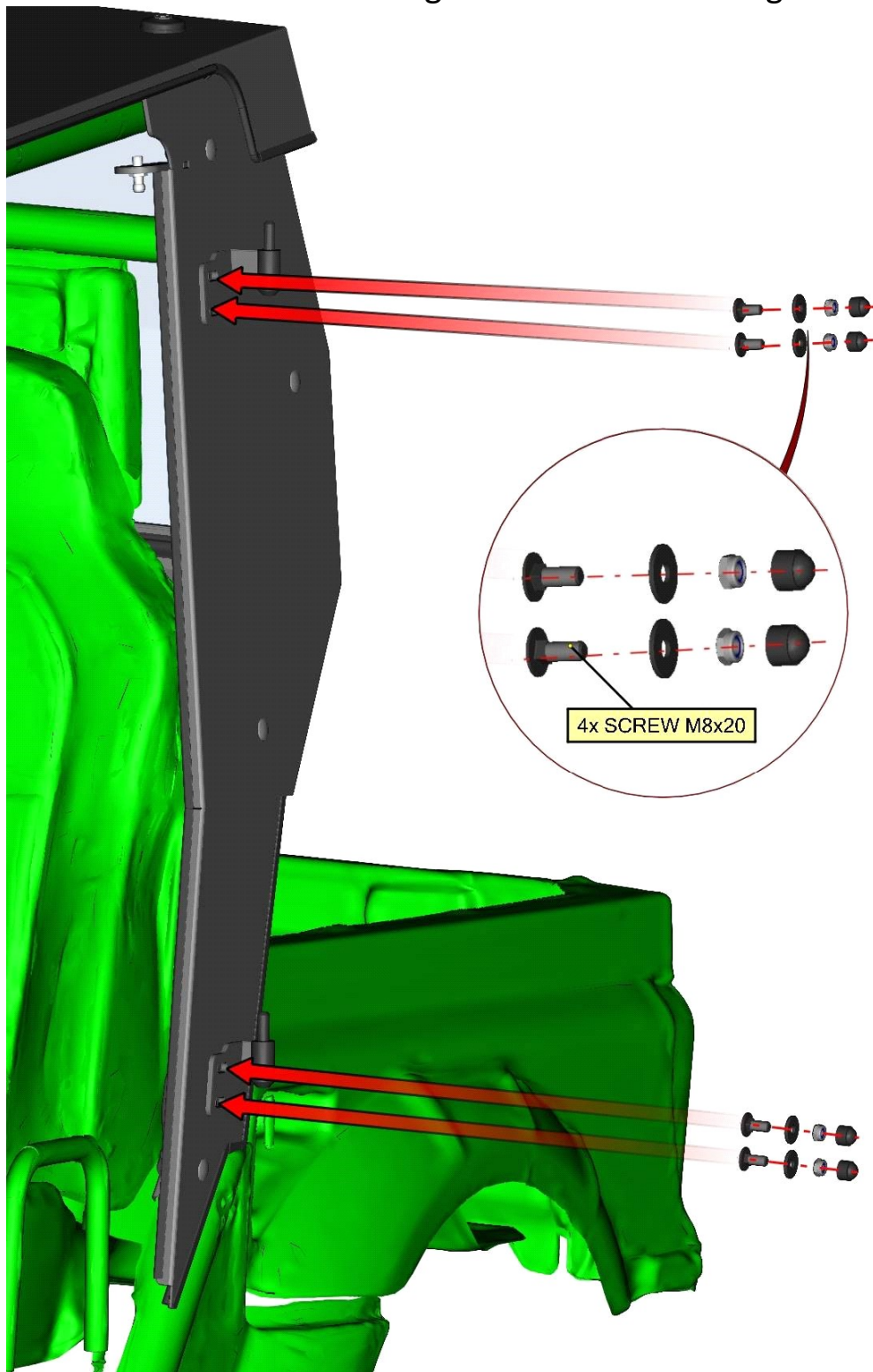

Install the washers onto the hinges pins. Lubricate the hinges pins and place the left door assembly onto the hinges.

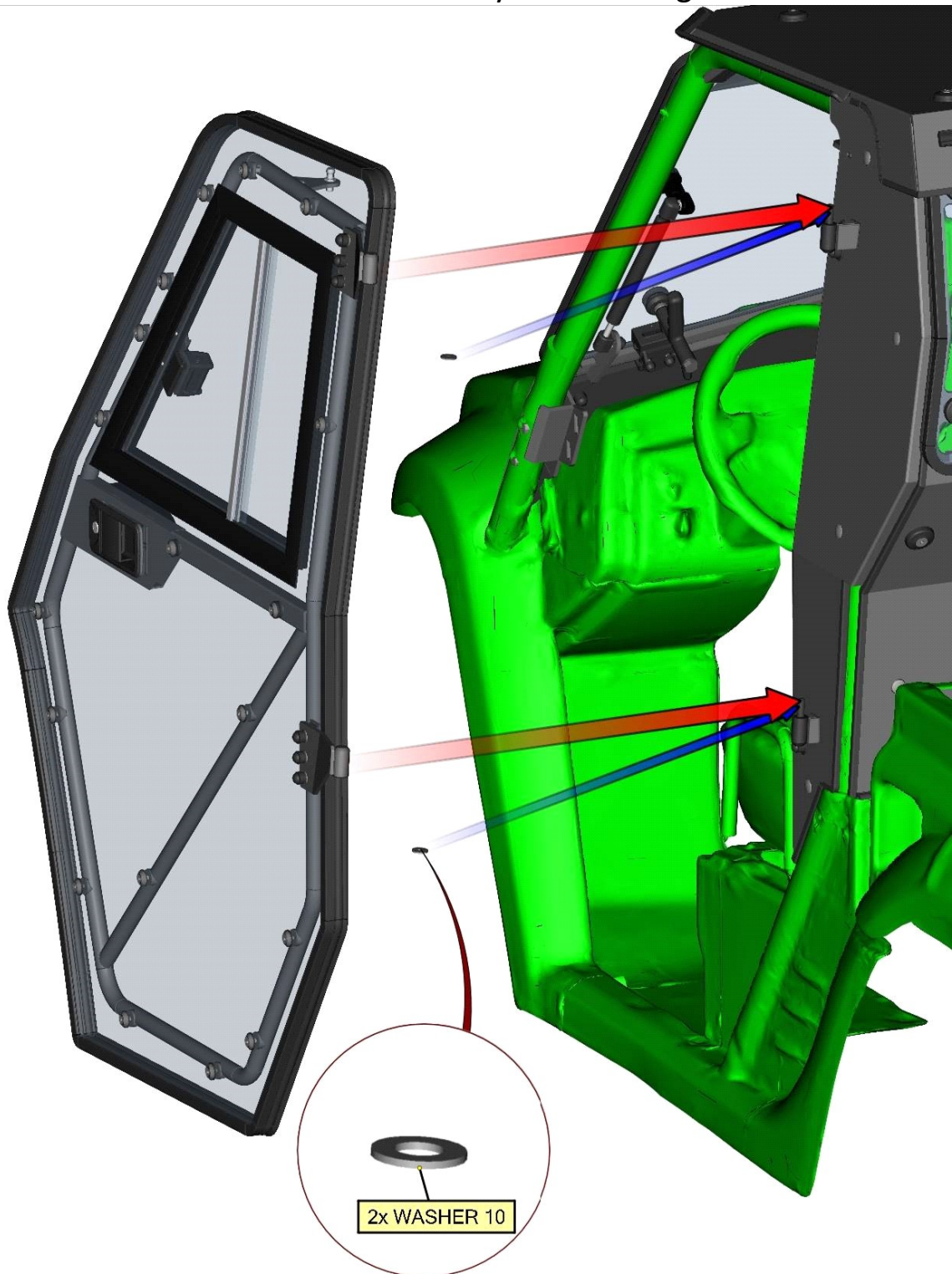

If necessary loosen the hinge screws and adjust the door to the best position and tighten the hinge screws securely.

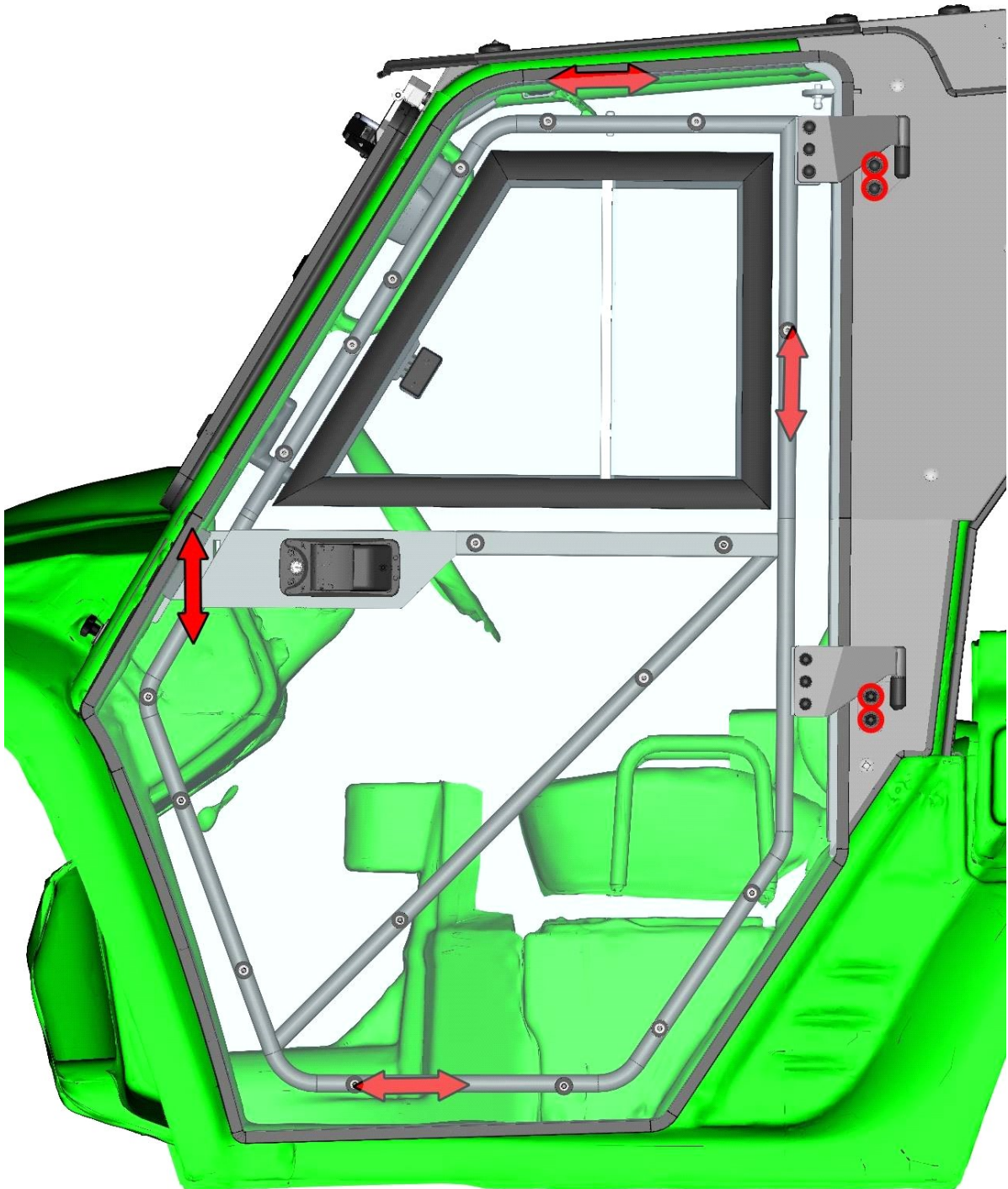

87

Place the left door stop assembly onto the left front bottom ledge holder.

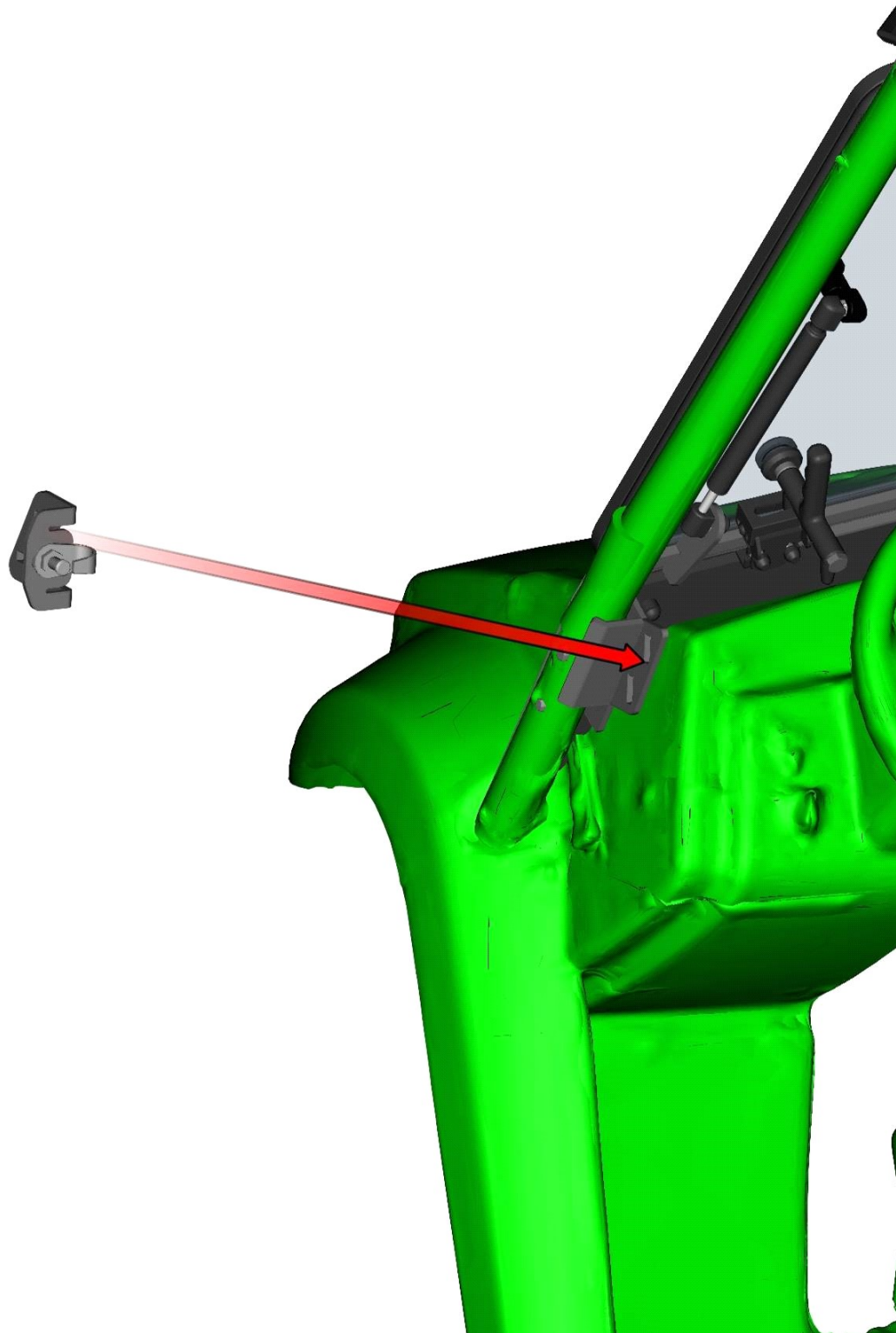

Attach the left door stop with included fixing assemblies.

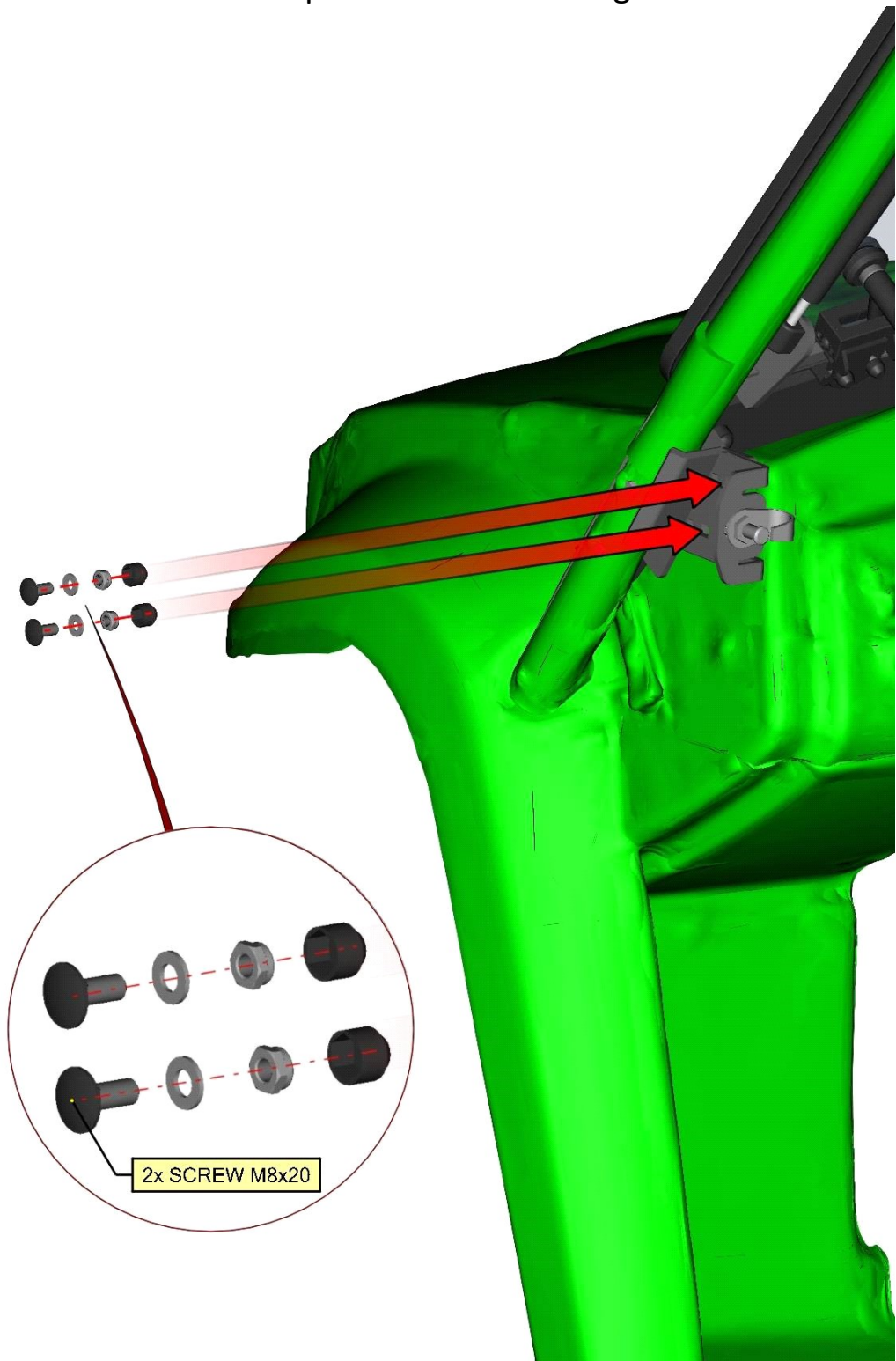

Mount the gas spring pins into the gas spring holders.

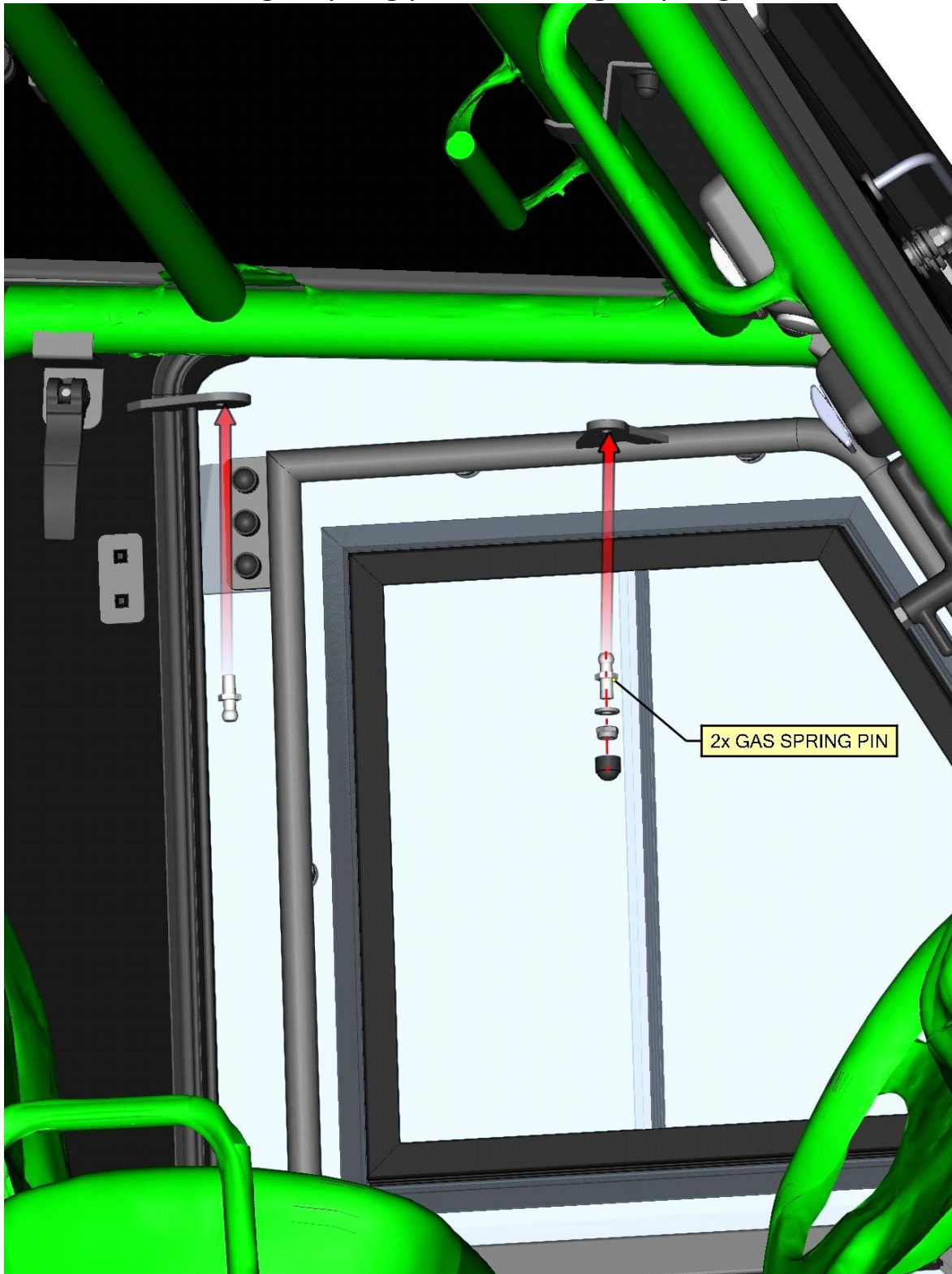

90

Install the gas spring onto the gas spring pins.

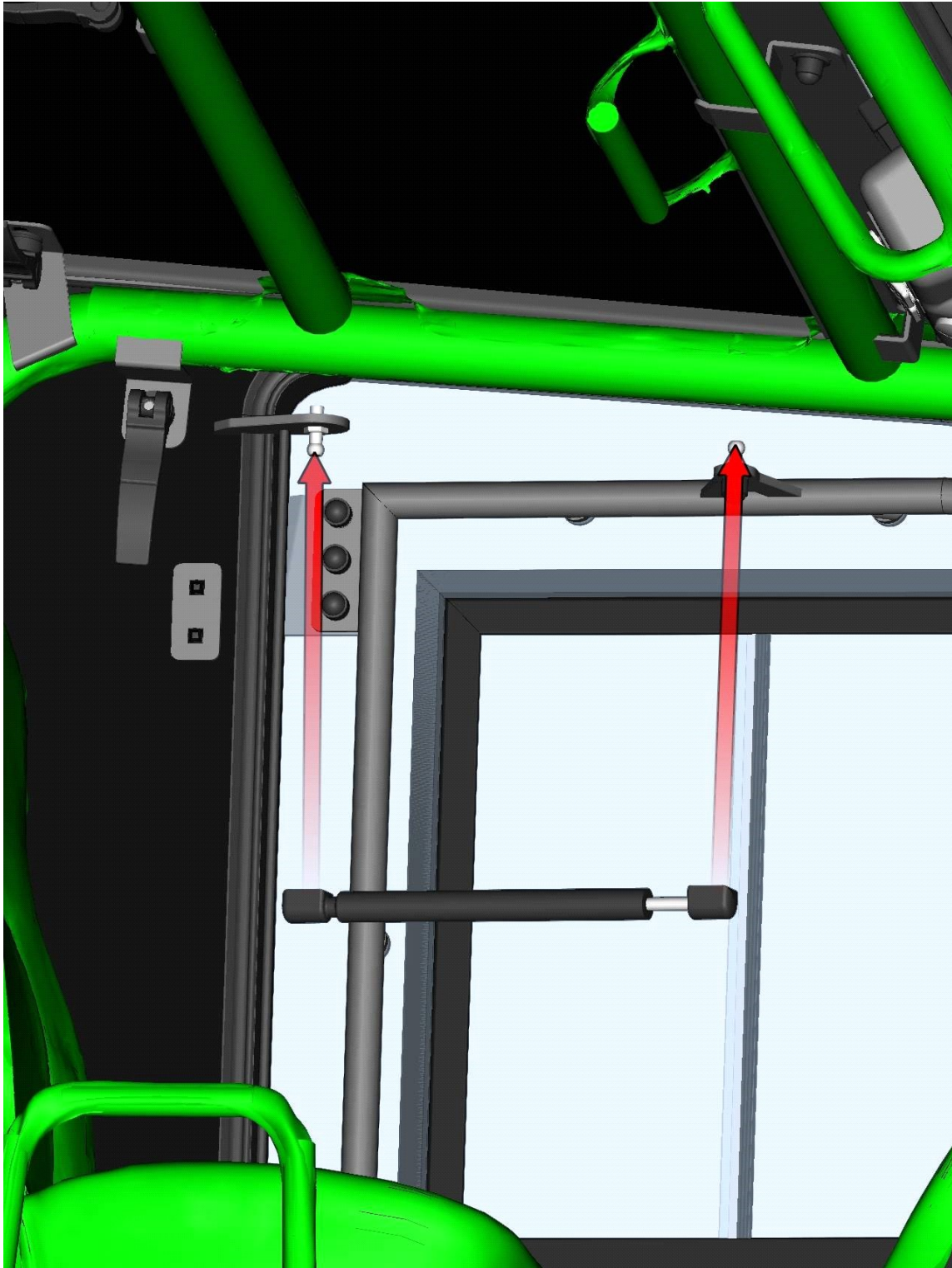

Remove two specific polycarbonate fixing assemblies from the door.

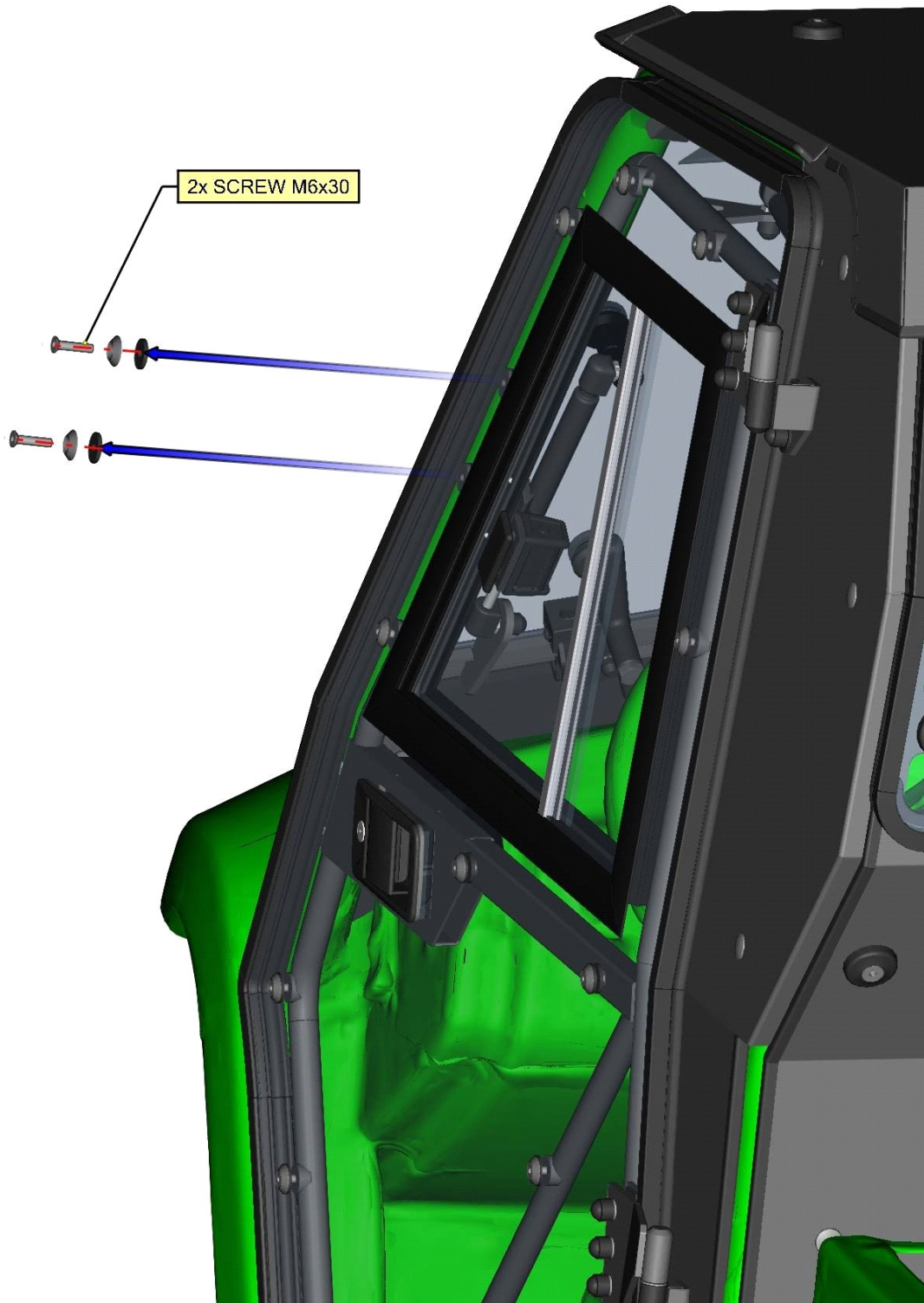

Mount the left rear view mirror on the left door with fixing assemblies removed in previous step.

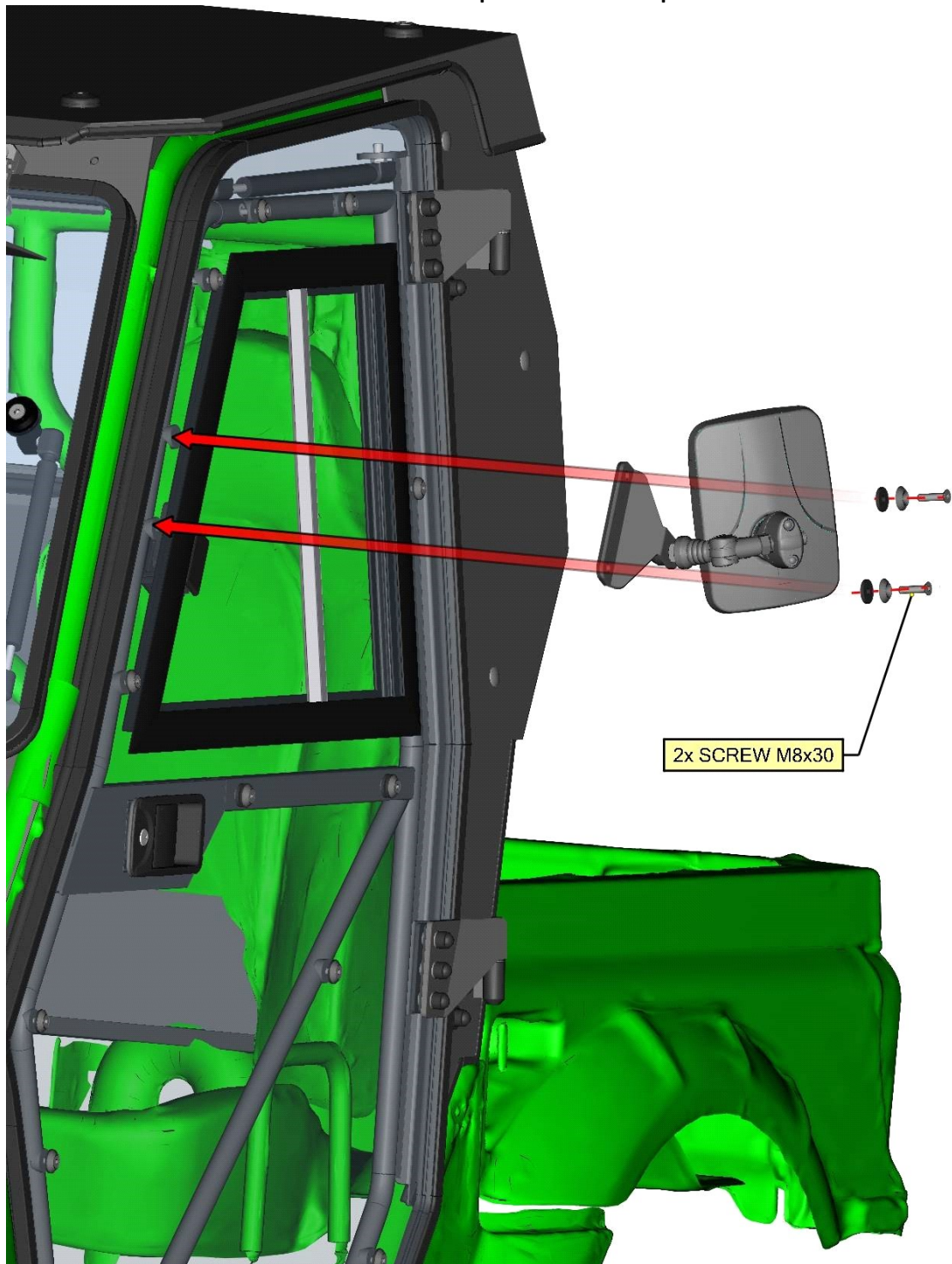

Repeat the previous steps with the right door assembly.

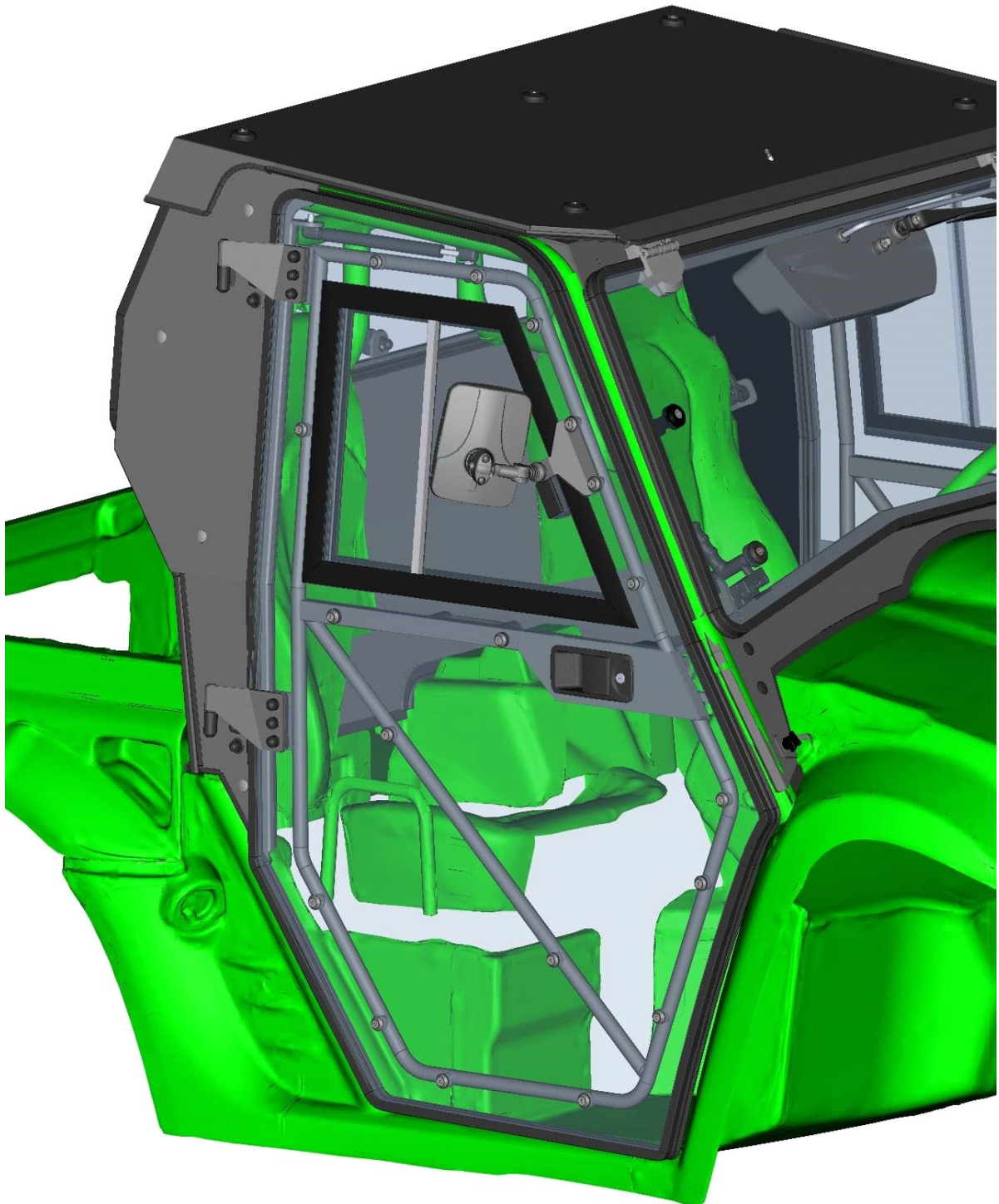



BOLT TORQUE

BOLT TORQUE SPECIFICATIONS

GENERAL TORQUE SPECIFICATION TABLE

Use the following torques when special torques are not given. These values apply to fasteners as received from suppliers, dry, or when lubricated with normal engine oil. They do not apply if special graphited or moly disulphide greases or other extreme pressure lubricants are used. This applies to both UNF and UNC threads. Remember to always use grade five or better when replacing bolts.

IMPORTANT: On all PLATED GRADE 8 bolts, reduce torque 15% from listed bolt torque specification.

SAE Grade No. Bolt head identification mark as per grade. NOTE: Manufacturing Marks Will Vary		2				5				8*			
													
Bolt Size		TORQUE				TORQUE				TORQUE			
		Pounds Feet		Newton-Meters		Pounds Feet		Newton-Meters		Pounds Feet		Newton-Meters	
Inches	Millimeters	Min.	Max.	Min.	Max.	Min.	Max.	Min.	Max.	Min.	Max.	Min.	Max.
1/4	6.35	5	6	7	8	9	11	12	15	12	15	16	20
5/16	7.94	10	12	14	16	17	20.5	23	28	24	29	33	39
3/8	9.53	20	23	27	31	35	42	48	57	45	54	61	73
7/16	11.11	30	35	41	47	54	64	73	87	70	84	95	114
1/2	12.70	45	52	61	70	80	96	109	130	110	132	149	179
9/16	14.29	65	75	88	102	110	132	149	179	160	192	217	260
5/8	15.88	95	105	129	142	150	180	203	244	220	264	298	358
3/4	19.05	150	185	203	251	270	324	366	439	380	456	515	618
7/8	22.23	160	200	217	271	400	480	542	651	600	720	814	976
1	25.40	250	300	339	406	580	696	787	944	900	1080	1220	1464
1-1/8	25.58	-	-	-	-	800	880	1085	1193	1280	1440	1736	1953
1-1/4	31.75	-	-	-	-	1120	1240	1519	1681	1820	2000	2468	2712
1-3/8	34.93	-	-	-	-	1460	1680	1980	2278	2380	2720	3227	3688
1-1/2	38.10	-	-	-	-	1940	2200	2631	2983	3160	3560	4285	4827

*Thick Nuts must be used with Grade 8 bolts

95

METRIC BOLT TORQUE SPECIFICATIONS

Size of Screw	Property Class	Course Thread			Fine Thread		
		Pitch (mm)	Pounds Feet	Newton-Meters	Pitch (mm)	Pounds Feet	Newton-Meters
M6	5.6	1.0	3.6-5.8	4.9-7.9	-	-	-
	8.8		5.8-9.4	7.9-12.7		-	-
	10.9		7.2-10	9.8-13.6		-	-
M8	5.6	1.25	7.2-14	9.8-19	1.0	12-17	16.3-23
	8.8		17-22	23-29.8		19-27	25.7-36.6
	10.9		20-26	27.1-35.2		22-31	29.8-42
M10	5.6	1.5	20-25	27.1-33.9	1.25	20-29	27.1-39.3
	8.8		34-40	46.1-54.2		35-47	47.4-63.7
	10.9		38-46	51.5-62.3		40-52	54.2-70.5
M12	5.6	1.75	28-34	37.9-46.1	1.25	31-41	42-55.6
	8.8		51-59	69.1-79.9		55-68	75.9-92.1
	10.9		57-66	77.2-89.4		62-75	84-101.6
M14	5.6	2.0	49-56	66.4-75.9	1.5	52-64	70.5-86.7
	8.8		81-93	109.8-126		90-106	122-143.6
	10.9		96-109	130.1-147.7		107-124	145-168
M16	5.6	2.0	67-77	90.8-104.3	1.5	69-83	93.6-112.5
	8.8		116-130	157.2-176.2		120-138	162.6-187
	10.9		129-145	174.8-196.5		140-158	189.7-214.1
M18	5.6	2.0	88-100	119.2-136	1.5	100-117	136-158.5
	8.8		150-168	203.3-227.6		177-199	239.8-269.6
	10.9		175-194	237.1-262.9		202-231	273.7-313
M20	5.6	2.5	108-130	146.3-176.2	1.5	132-150	178.9-203.3
	8.8		186-205	252-277.8		206-242	279.1-327.9
	10.9		213-249	288.6-337.4		246-289	333.3-391.6

